

INTRODUCTION

This manual is intended as a reference for the installation and service of a Scotsman ice maker model CME865R or CME1002R.

This model is a remote condenser cuber, 30" wide and should be connected to a Scotsman remote condenser.

Table of Contents

| | |
|--|---------|
| INTRODUCTION | Page 1 |
| PRE-INSTALLATION INFORMATION | Page 2 |
| ICE MACHINE SPECIFICATIONS | Page 3 |
| RCE1001 SPECIFICATIONS | Page 4 |
| FOR THE INSTALLER: Environmental Limitations | Page 5 |
| FOR THE INSTALLER: Machine & Bin Assembly | Page 6 |
| FOR THE PLUMBER | Page 7 |
| FOR THE INSTALLER: Remote Condenser | Page 8 |
| FOR THE INSTALLER: Coupling Instructions | Page 9 |
| FOR THE ELECTRICIAN: Electrical Connections | Page 10 |
| FOR THE INSTALLER: Final Check List | Page 11 |
| INITIAL START UP | Page 12 |
| ADJUSTMENTS | Page 14 |
| COMPONENT DESCRIPTION | Page 15 |
| SERVICE SPECIFICATIONS: CME865R | Page 18 |
| SERVICE SPECIFICATIONS: CME1002R | Page 19 |
| CLEANING & SANITIZING | Page 20 |
| CLEANING | Page 21 |
| FREEZING CYCLE OPERATION | Page 22 |
| HARVEST CYCLE - HOT GAS BYPASS | Page 23 |
| SERVICE DIAGNOSIS | Page 24 |
| SERVICE DIAGNOSIS: Ice Level Control Circuit | Page 26 |
| REMOVAL AND REPLACEMENT | Page 27 |
| REFRIGERATION SERVICE | Page 31 |
| LIQUID CHARGING | Page 32 |

Parts lists and wiring diagrams are in the center of this manual, printed on yellow paper.

*This manual was printed on recycled paper.
This manual contains information on maintenance
and service. Keep it for future reference.*

Note this symbol where it appears.



It marks a potential hazard.

CME865R & CME1002R

PRE-INSTALLATION INFORMATION

These two models are modular ice cube machines that are designed to be connected to a remote condenser.

The remote condenser coil must be of adequate size and must NOT have been used with a mineral oil refrigeration system. Specific Scotsman remote condensers are recommended.

A stacking kit (KSCMS) is required for stacking these ice machines. It interconnects the sonar bin ice level controls. A CME865 or CME1002 may **only** be stacked onto models CME865, CME1002, MCM860, MCM1062 or CMS1002.

These models will fit any 30" wide Scotsman bin, such as the BH550 or HTB555, without a bin top. Other bins require a bin top.

Note: The sonar transducer, located in the base of the machine, must NOT be covered by installation material (such as a non-Scotsman bin top). The transducer must have clear access to the ice to be able to sense the ice level. See page 5 for location.

| Model Number | Dimensions W" x D" x H" | Basic Electrical | Min Circuit Ampacity | Max Fuse Size | Refrigerant Charge* (R-404A) |
|---------------|----------------------------|------------------|-------------------------|------------------|---------------------------------|
| CME865RE-32A | 30 x 24 x 27 | 208-230/60/1 | 16.5 | 20 | 336 oz. |
| CME865RE-6A | 30 x 24 x 27 | 230/50/1 | - | - | 336 oz. |
| CME1002RE-32A | 30 x 24 x 27 | 208-230/60/1 | 20.5 | 20 | 336 oz. |
| CME1002RE-3A | 30 x 24 x 27 | 208-230/60/3 | 14.3 | 15 | 336 oz. |
| CME1002RE-6A | 30 x 24 x 27 | 230/50/1 | - | - | 336 oz. |

* This number is for recharging purposes only. - Note: Beginning June 1996, 48 ounces of charge were added to the ERC301, before that total charge was 288 oz.

Use Scotsman Remote Condenser

- RCE1001 (single circuit) or ERC301 (single circuit).

Use precharged tubing kit

- RTE25 (25')
- RTE40 (40')
- RTE75 (75')



| | Air Temperature (cabinet) | Remote Condenser Air Temperature | Voltage | Water Temperature |
|---------|------------------------------|-------------------------------------|---------|---------------------|
| Minimum | 50 ⁰ F. | -20 ⁰ F. | -5% | 40 ⁰ F. |
| Maximum | 100 ⁰ F. | 120 ⁰ F. | +10% | 100 ⁰ F. |

ICE MACHINE SPECIFICATIONS

Always refer to the nameplate, located on the back of the cabinet, for the:

- model number,
- serial number,
- basic electrical requirements,
- minimum circuit ampacity,
- maximum fuse size,
- and refrigerant charge.

| | |
|--------------------------------|---------|
| MODEL NUMBER | WIRE |
| SERIAL NUMBER | HERTZ |
| A.C. SUPPLY VOLTAGE | PHASE |
| MINIMUM CIRCUIT AMPACITY | |
| MAXIMUM FUSE SIZE * | |
| HEATER WATTS | |
| REFRIGERANT CHARGE | OZ. |
| MOTORS | VOLTS |
| COMPRESSOR | RLA/FLA |
| FAN | WHP. |
| DRIVE | LRA |
| OTHER | |
| DESIGN PRESSURE | LOW |
| | HIGH |
| * OR HACR TYPE CIRCUIT BREAKER | |



 FAIRFAX OPERATION
 FAIRFAX, SOUTH CAROLINA U.S.A.

A serial number plate with the model number, serial number and refrigerant charge is located behind the front panel, below the control box.

The unit comes from the factory with the correct refrigerant charge contained in the receiver. The refrigerant charge information is for recharging, should that be necessary.

All utility connections and refrigerant line connections are made at the back of the ice maker.

Before beginning installation, be sure that all of the components necessary for complete assembly of the ice system are available, and are the correct components with regard to model, voltage, and finish.

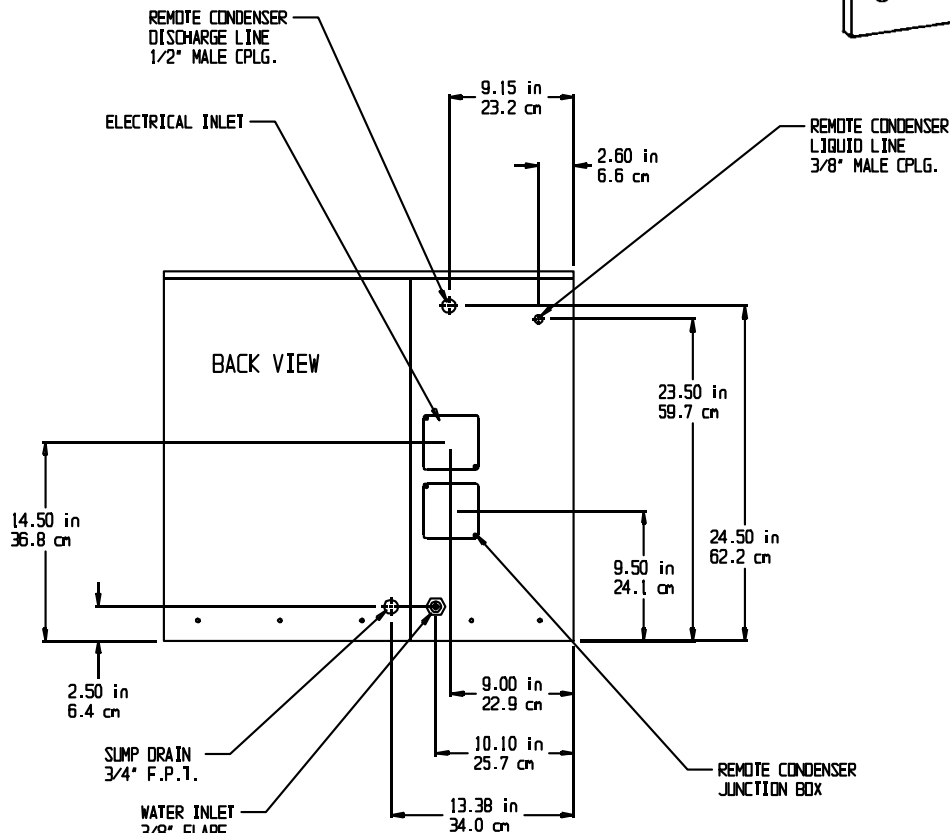
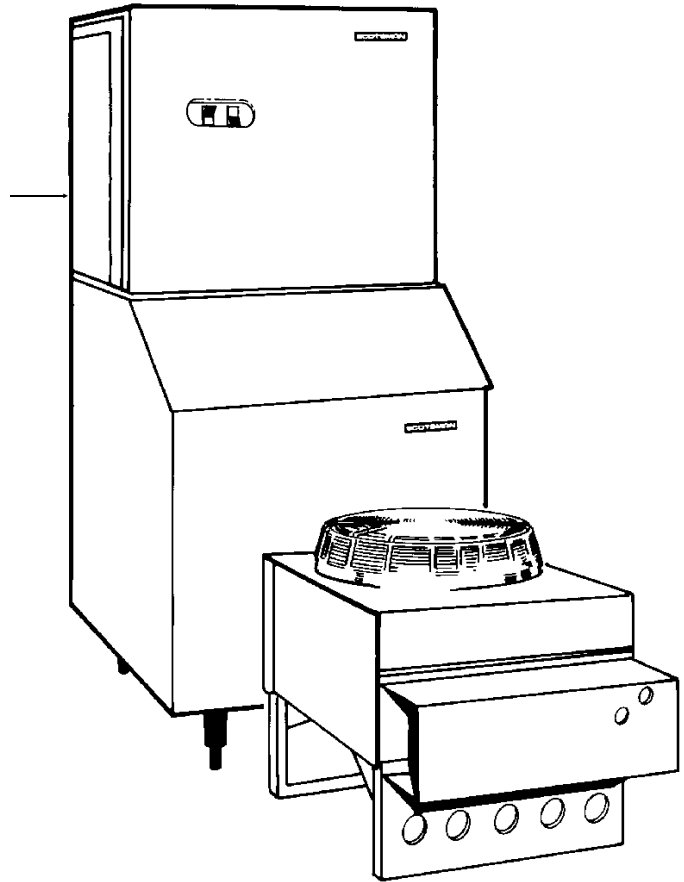

CME865R & CME1002R

ERC301 SPECIFICATIONS

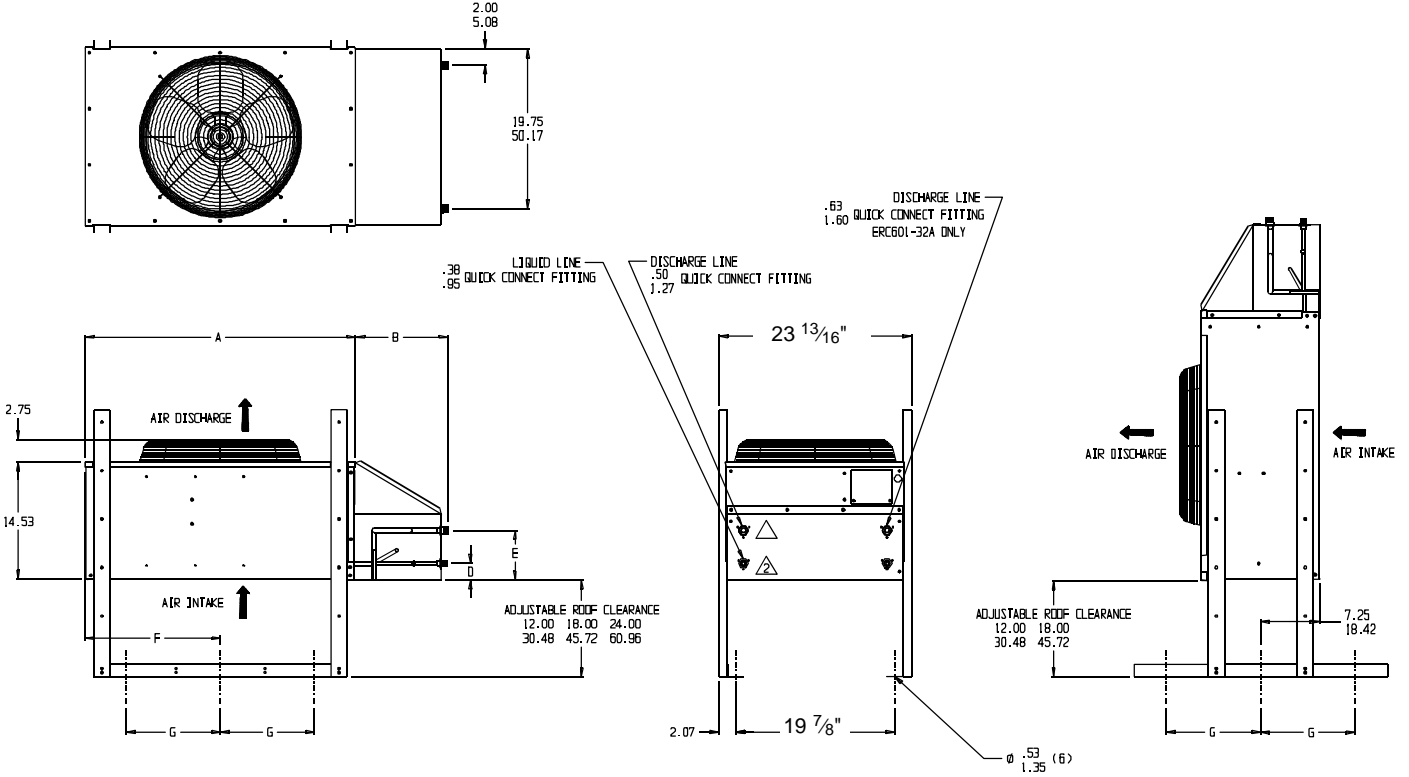

ERC Dimensions

| A | B | F | G |
|---------|---------|---------|---------|
| 33 3/8" | 10 3/4" | 16 3/4" | 11 5/8" |

CME865R & CME1002R

FOR THE INSTALLER: Environmental Limitations

Installation Limitations

The ice making portion of this ice system is designed to be installed **indoors**, in a controlled environment.

| | Minimum | Maximum |
|----------------|--------------------|---------------------|
| Air Temp | 50 ⁰ F. | 100 ⁰ F. |
| Water Temp | 40 ⁰ F. | 100 ⁰ F. |
| Water Pressure | 20 PSI | 80 PSI |
| Voltage | 197 | 253 |

Operating the ice machine outside of the above limitations, or outdoors, is potentially damaging to the machine; also it is misuse of the machine, which may void the warranty.

Scotsman Ice Systems are designed and manufactured with the highest regard for safety and performance. They meet or exceed the standards of UL, NSF, and CSA.

Scotsman assumes no liability or responsibility of any kind for products manufactured by Scotsman that have been altered in any way, including the use of any part and/or other components not specifically approved by Scotsman.

Scotsman reserves the right to make design changes and/or improvements at any time.

Specifications and design are subject to change without notice.

Water Limitations

An ice machine is a food manufacturing plant; it takes a raw material, water, and turns it into a food product, ice. The purity of the water is very important in obtaining pure ice and in maximizing product life. These general recommendations should help keep the ice maker clean:

1. Filter the water used to produce ice. Water filters vary greatly in ability and function. Install one that filters out suspended solids to a dimension of 5 microns or smaller. The finer the filter the better, but finer filters will clog sooner than course ones. It may be necessary to add a course filter ahead of the fine filter to prolong filter life.
2. Check with a water treatment specialist for a water test, and recommendations regarding filters and treatment.

Service Limitations

Some space on the sides, the back and the top should be allowed for service and utility connections.

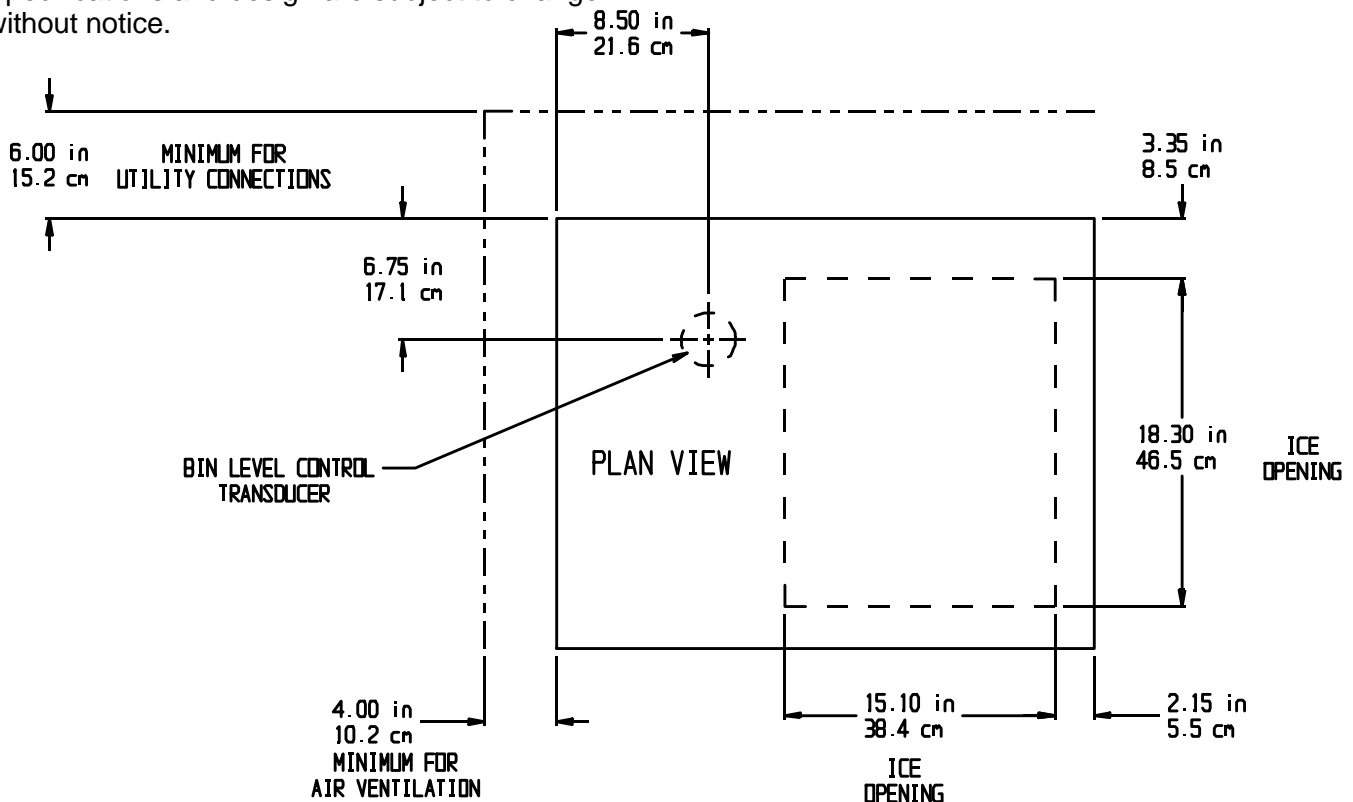

CME865R & CME1002R

FOR THE INSTALLER: Machine & Bin Assembly

Overview:

This ice system consists of 4 major assemblies:

1. The ice storage bin.
2. The ice maker itself.
3. The interconnecting refrigerant lines.
4. The remote condenser.

Additionally, there will be interconnecting wires between the ice maker and the condenser. The Scotsman remote condenser is powered from the ice maker. The condenser must be located above the ice maker, usually on the roof.

On the back of the cabinet is the following notice:

REMOTE CONDENSER NOTICE

This unit has been designed for use with Underwriter's Laboratories Inc. listed forced air cooled condensers, Scotsman models RCE1001-32A or RCE1002-32A or ERC301. The ice maker, condenser and connecting line sets are factory charged with the correct amount of refrigerant and therefore require no charging in the field unless the system should be opened for service repairs.

If other forced air cooled condensers are being considered for use with this ice maker, prior approval from Scotsman is necessary to insure proper system operation.

Any alternate forced air cooled condenser being considered must be listed with Underwriters Laboratories, Inc. Certified with C.S.A. and have a minimum design pressure of 500 P.S.I.G.

CAUTION

A suitable ground path must be provided between the remote condenser cabinet and the ice maker cabinet if the condenser fan is powered from the ice maker.

IMPORTANT

In order to prevent compressor damage due to refrigerant migration, and to insure acceptable start up, a crankcase heater has been installed on the compressor. This heater is wired to operate at all times. Upon initial start up and any time the unit power supply is interrupted for more than one hour, the machine should not be started for at least 4 hours after the power supply has been reconnected to the machine.

Storage Bin:

1. Measure the location of the ice machine floor drain relative to the installed location of the bin. Route all drain lines so that when the machine is installed in its normal position, the drain tubes terminate just above the floor drain.
2. Using corner posts from the bin's carton as a cushion, lay the bin on its back.
3. Install the legs into the leg sockets.
4. Move bin back to an upright position.
5. Remove all material that is packed inside the bin.

Ice Maker:

1. Arrange for proper electric, water and drain.

See instructions for the plumber and for the electrician.

2. Position the ice storage bin in the selected location which should have a minimum room temperature of 50-degrees F. and maximum room temperature of 100 degrees F.
3. Inspect the bin top mounting gasket which should be flat, with no wrinkles, to provide a good water seal when the cuber is installed on top of the bin.
4. Install the modular cuber on top of the bin using care to be sure a good seal is made between the two cabinets, use of a mechanical lift is recommended. Align the holes in the bottom back of the cabinet to mate with the two mounting straps on the top rear of the bin.
5. Use bolts and straps found in the hardware package to secure the ice machine to the ice storage bin.

When alignment and leveling are completed, tighten the bolts to secure the mounting straps.

Remote Condenser:

A **new** condenser coil designed for the machine's capacity **MUST** be used. Because of the possibility of mineral oil contamination, **coils and line sets** that had been connected to R-12, R-502 or R-22 units **MAY NOT BE CONNECTED TO THIS SYSTEM**. Doing so voids the refrigeration system warranty.

FOR THE PLUMBER

Water Supply

The recommended water supply line is a 3/8-inch O.D. tubing with a minimum operating pressure of 20 PSIG and a maximum of 80 PSIG.

Connect to cold water supply line with standard plumbing fittings, with shut off valve installed in an accessible place between the water supply and the cuber. In some cases a plumber will be required.

Drain Connections:

All drains are gravity type and must have a minimum of 1/4 inch per foot fall on horizontal runs.

The drains to be installed must conform with the local plumbing codes. Use only 3/4" rigid tubing. The ice machine's drain must be separate from the bin's drain. Both use 3/4" FPT fittings. Insulation of the bin drain is recommended.

Install a vertical open vent on the drain line(s) high point to ensure proper draining. The ideal drain receptacle is a trapped and vented floor drain.

CONFORM TO ALL LOCAL CODES.

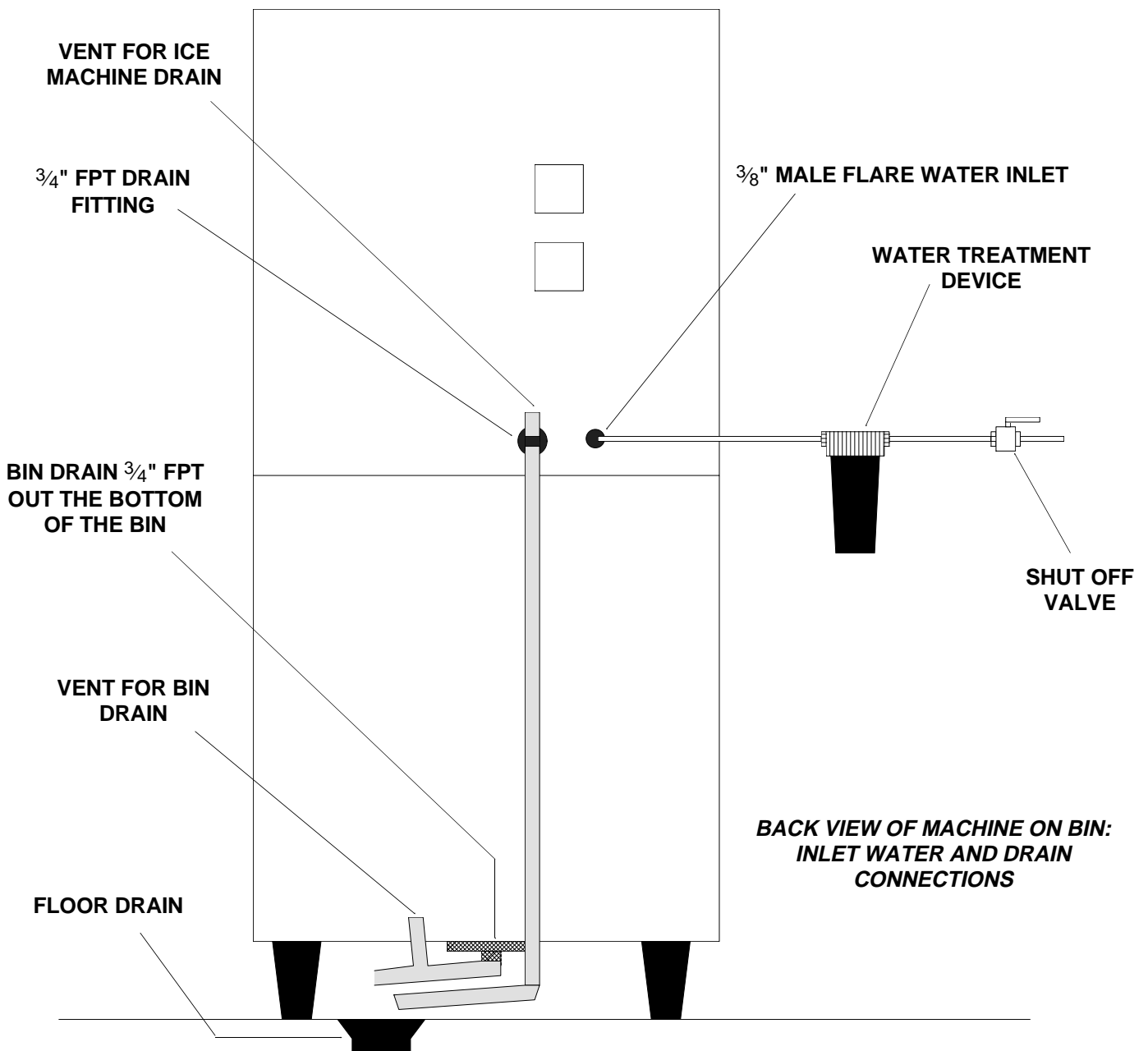

CME865R & CME1002R

FOR THE INSTALLER: Remote Condenser

Locate the condenser as near as possible to the interior location of the ice maker.

Location of the condenser is limited by the specific length of pre-charged refrigerant tubing supplied for the application. The pre-charged tubing connects the ice maker to the remote condenser. The condenser must be above the ice maker.

Select the best available location, protecting the condenser from extremes of dirt, dust, and sun.

Meet all applicable building codes.

Roof Attachment:

Install and attach the remote condenser unit to the roof of the building, using the methods and practices of construction that conform to the local building codes, including having a roofing contractor secure the condenser to the roof.

Pre-charged Line Routing

CAUTION

Do not connect pre-charged tubing until all routing and forming of the tubing is complete. See the coupling instructions for connecting instructions.

1. Each set of precharged refrigerant lines consists of a 3/8 inch diameter liquid line, and a 1/2 inch diameter discharge line. Both ends of each line have quick connect couplings, one end has access valves: that end goes to the ice maker.

Note: The openings in the building ceiling or wall, listed in the next step, are the minimum sizes recommended for passing the refrigerant lines through.

2. Have the roofing contractor cut a minimum hole for the refrigerant lines of 1.75". Check local codes, a separate hole may be required for the electrical power to the condenser.

CAUTION

DO NOT KINK OR CRIMP REFRIGERANT TUBING WHEN INSTALLING IT.

3. Route the refrigerant lines through the roof opening.

Follow straight line routing whenever possible.

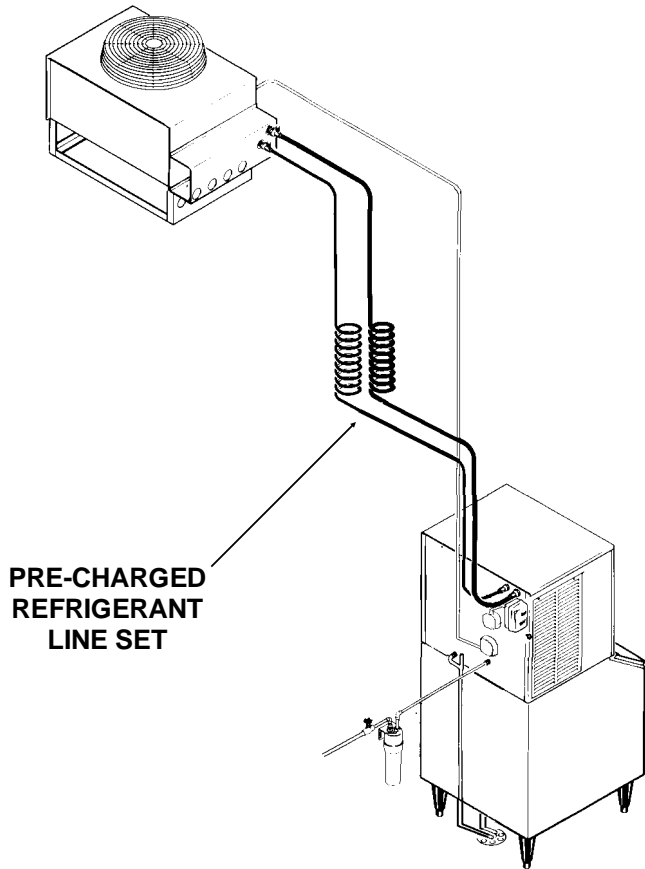

Any excess tubing **MUST** be retained within the building.

4. Spiral any excess length of pre charged tubing inside the building. Use a horizontal spiral (as illustrated) to avoid any traps in the lines.

Note: Actual spiral need not be as tight as shown.

5. Have the roofing contractor seal the holes in the roof per local codes.

Note: Only a holding charge is in the precharged line set.

CME865R & CME1002R

FOR THE INSTALLER: Coupling Instructions

CAUTION

The couplings on the sets of precharged lines are self sealing when installed properly. Carefully follow the instructions:

1. Remove the protector caps and plugs. Wipe the seats and threaded surfaces with a clean cloth to be certain that no foreign matter remains on them.
2. Lubricate the inside of the couplings, especially the O-Rings with refrigerant oil.
 - The 3/8 inch liquid line (schrader valve end) goes to the remote condenser fitting marked "liquid line".
 - The other end of the liquid line goes to the ice maker fitting marked "liquid line."
 - The 1/2 inch discharge line (schrader valve end) goes to the remote condenser fitting marked "discharge line".
 - The other end of the discharge line goes to the ice maker fitting marked "discharge line".

3. Begin tightening the couplings together by hand, then using two wrenches (it is important that **ONLY** the nut on the precharged lines be turned, the other parts of the couplings must **NOT** be allowed to turn or the process will tear out the diaphragms and they will be loose in the refrigeration system) tighten the coupling until it bottoms out or a definite increase in resistance is felt.

**ONLY TURN NUT ON
TUBING KIT, HOLD
TUBING STATIONARY**

**USE TWO
WRENCHES**

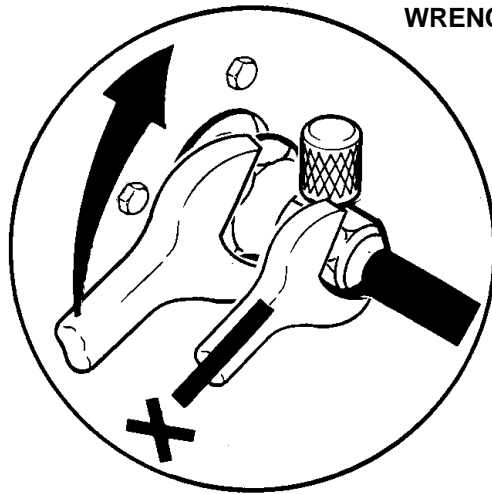

4. Using a marker or pen, mark a line lengthwise from the coupling union nut to the bulkhead. Then tighten the coupling and additional 1/4 turn. As the nut turns, the line will show when 1/4 turn is made.
5. After all connections are made, and after the king valve has been opened, check the couplings for leaks.

CME865R & CME1002R

FOR THE ELECTRICIAN: Electrical Connections

See the NAMEPLATE for current requirements to determine wire size to be used for electrical hookup. The cuber requires a solid chassis to chassis earth ground wire. See Wiring Diagram.

Be certain the cuber is connected to its own electrical circuit and individually fused. Voltage variation should not exceed ten percent of the nameplate rating, even under starting conditions. Low voltages can cause erratic operation and may be responsible for serious damage to the ice maker.

Electrical connections are made at the rear of the ice maker, inside the junction box.

CAUTION

Do **not** switch the ice maker on at this time, make certain the master and compressor switches are OFF when power is connected to the ice maker. Power must be connected to the ice maker long enough in advance of start up to allow the crankcase heater to warm the compressor, usually about 12 hours.

Scotsman Condenser:

Separate electrical connections are made from the ice maker to the condenser, as there is line power interconnecting the ice maker to the condenser.

All external wiring should conform to the national, state and local electrical code requirements. Usually an electrical permit and services of a licensed electrician will be required.

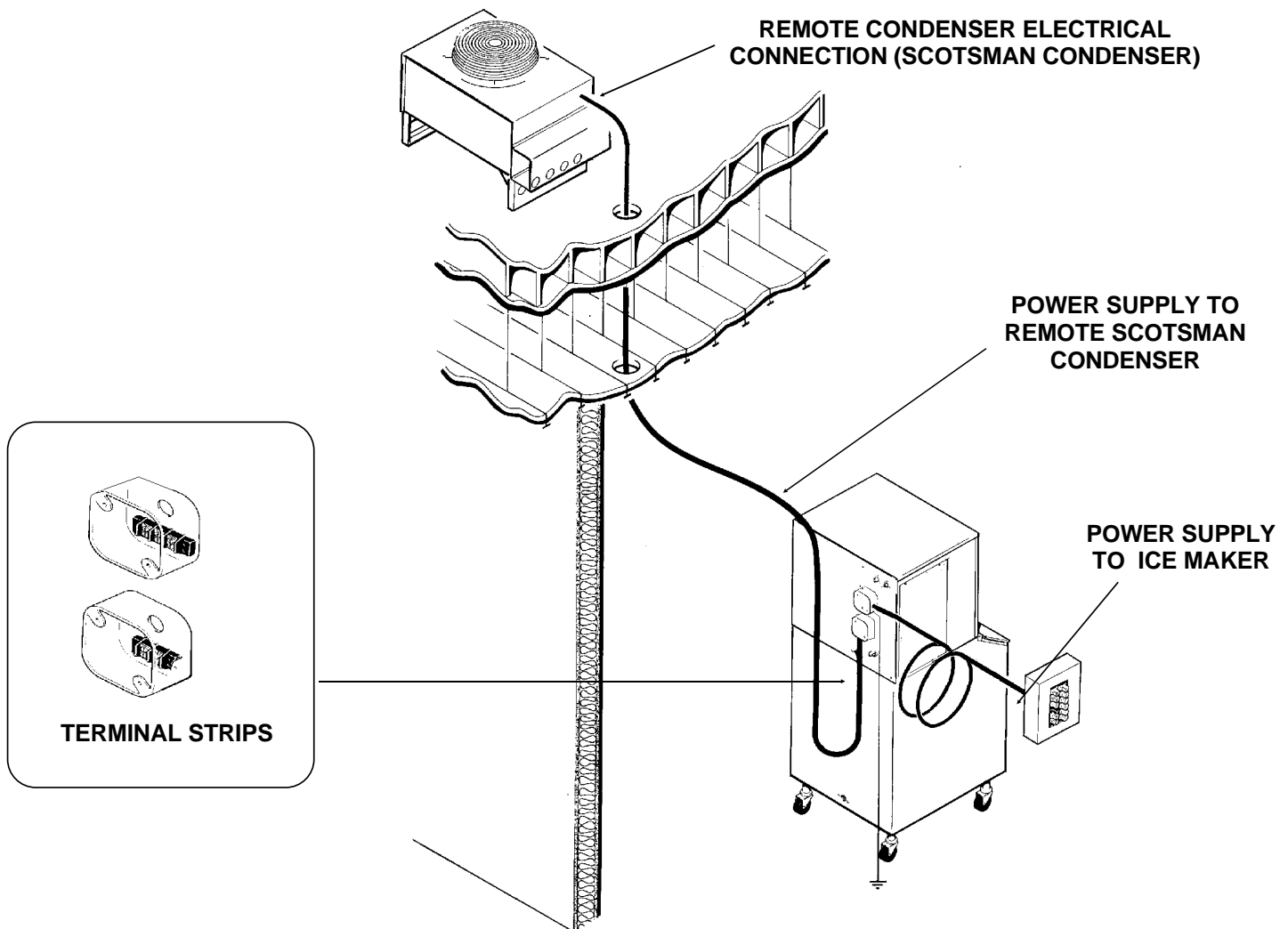

FOR THE INSTALLER: Final Check List

1. Is the ice maker cabinet in a room where ambient temperatures are within the minimum and maximum temperatures specified?
2. Is there clearance at both sides of the cabinet and at the back and top for service and utility connections?
3. Has water supply pressure been checked to insure a minimum of 20 PSIG and a maximum of 80 PSIG operating pressure?
4. Is the cabinet level?
5. Check that any shipping material has been removed from inside the cabinet.
6. Have all electrical and piping connections been made?
7. Are the On/Off/Wash and Compressor switches set to the OFF position?
8. Has power been connected to the ice maker?
9. Is the water supply line shut off valve installed?
10. Check all refrigerant lines and conduit lines, to guard against vibration or rubbing and possible failure.
11. Have the bin and cabinet been wiped clean and sanitized?
12. Has the Field Quality Audit form been properly filled out? Check for correct model and serial numbers from Serial nameplate, then mail the completed form to the SCOTSMAN factory.
13. Has the owner been given the name and telephone number of the authorized SCOTSMAN Service Agency serving him?

CME865R & CME1002R

INITIAL START UP

Remote Condenser:

1. Check that all connections have been made.

Ice Maker:

1. Remove front panel by pulling out to unsnap.
2. Remove two screws and the control box cover.
3. Remove the evaporator cover.
4. Remove the left side service panel.
5. Check that the ON/WASH/OFF rocker switch and the Compressor ON-OFF toggle switch are in the OFF position, on the control box.
6. Locate and open the king (service) valve on the receiver. Check that the crankcase heater has been on long enough to warm the compressor dome (about 4 hours).
7. OPEN the water supply line shut off valve.
8. Inside the control box is the shaft of the timer and the switch assembly. Rotate the shaft of the timer and switch assembly clockwise to where the actuator arm on the micro switch drops off outer cam into cam slot. See Timer Cam Positions.
9. Move the ON/WASH/OFF rocker switch to the ON position.

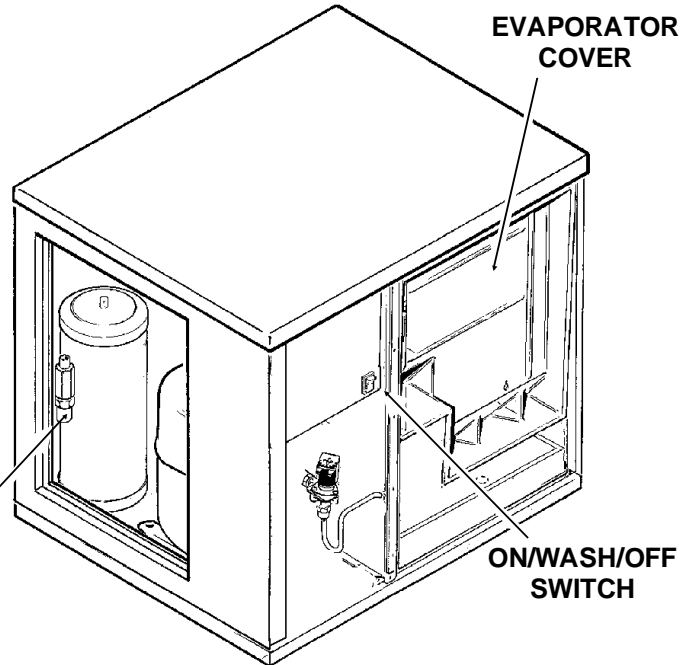

10. Observe water fill cycle: The water pump will be operating and the water inlet solenoid valve will OPEN. Incoming water flows from the valve through the tubing, the reservoir fills and excess water drains out the machine drain.

At the end of the harvest cycle, the water inlet solenoid valve will close and the water fill cycle is complete. If the reservoir is not full, turn the shaft of the timer clockwise into a new harvest cycle; this opens the water valve again.

The water pump pumps water up to the water distributor at the top of each evaporator plate, where water is uniformly dispensed, cascades down both sides of each evaporator plate and drains back into the reservoir for recirculation.

11. Check that the water cascades down over the cube molds and into the reservoir. Note: some spray is normal when the machine is new.

12. When the reservoir is full, move the compressor ON-OFF switch, to the ON position.

13. Observe the first freezing cycle: Feel the metal parts of the evaporator plate; they should feel cold, and very shortly ice will begin to form. The tubing will become frosted at the top of the evaporator plate. Freezing time will be longer than average for the first cycle. Average complete cycle time is about 13 - 16 minutes.

TIMER CAM POSITIONS

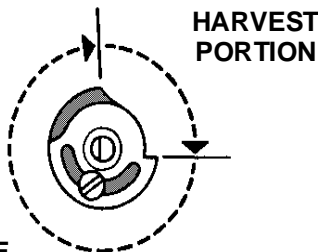
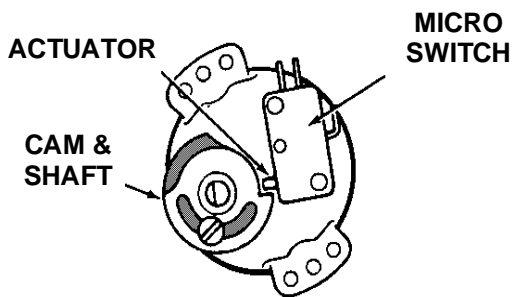

**FREEZE
PORTION**

INITIAL START UP

14. Check CUBE SIZE

The dimensions of the cubes are fixed by the size and shape of the molds on the evaporator plate, except that the thickness of the cube *MAY* need to be adjusted at start up. There is only one size of cube that is correct; adjusting the cube size control to that size of cube will allow the ice maker to produce ice at its most efficient size. The correct size cubes will be fully formed at the edges; will harvest off of the evaporators beginning with individual cubes at the top of the evaporator, then vertical strips for the balance; and will appear similar to the illustration for "Correct Size Cube".

Adjust for the correct size if needed:

To produce **SMALLER** sized ice cubes:

Locate cube size control knob, in the front of the control box. Rotate this knob one eighth of a turn counter clockwise. Observe size of the ice cubes in the next ice cube harvest and adjust again if needed, until the correct ice cube is achieved.

To produce **LARGER** ice cubes:

Locate cube size control on the front of the control box. Rotate the knob one eighth of a turn clockwise. Observe size of ice cubes in the next cube harvest and adjust again until correct the ice cube size is achieved.

15. Check harvest time. The machine must harvest all of the cubes before returning to a freeze cycle.

Increase the harvest time if there is less than 15 seconds of harvest time after the last cube has fallen into the bin.

Decrease the harvest time if there is much more than 15 seconds of harvest time after the last cube has fallen into the bin. Note: Harvest time is dependent upon the water and air temperatures at the ice machine. Do not adjust harvest time too short, as this will cause a freeze up.

See the next page for detailed harvest time adjustment instructions.

16. Check ICE BIN LEVEL CONTROL

The amount of ice maintained in the bin is adjustable. The normal setting is "full". If desired, the machine may be adjusted to shut off the machine when the bin is only partially full.

1. Open the bin door and locate on the bottom of the ice machine, the ice level sensor. It's in a

CUBES (ACTUAL SIZE)

TOO THICK

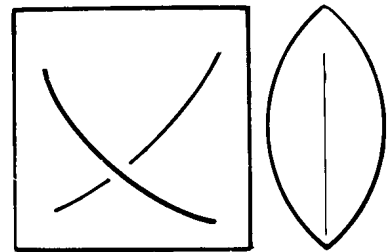

CORRECT SIZE CUBE

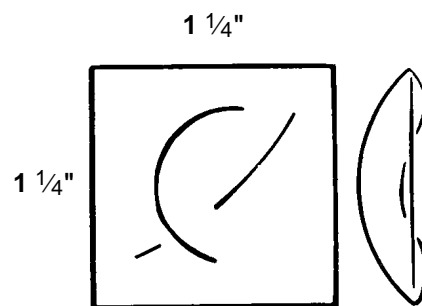

Note: Optimum performance will be achieved when the ice machine is adjusted to produce this size and shape of cube. The typical batch weight at this setting is between 8.25 and 9 pounds.

TOO THIN

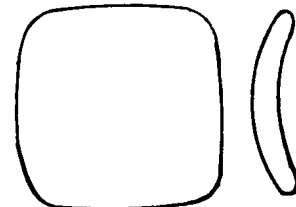

socket about 2" in diameter and located left of the evaporator plates.

2. When the machine is running, wait until near the end of a "harvest" cycle.

3. Hold a flat object about the size of this service manual over the ice level sensor socket.

4. The ice machine should turn off at the end of the harvest cycle.

5. Slowly lower the flat object straight down.

6. The ice machine will start again at the point where it will maintain the ice level.

17. Replace all panels.

CME865R & CME1002R

ADJUSTMENTS

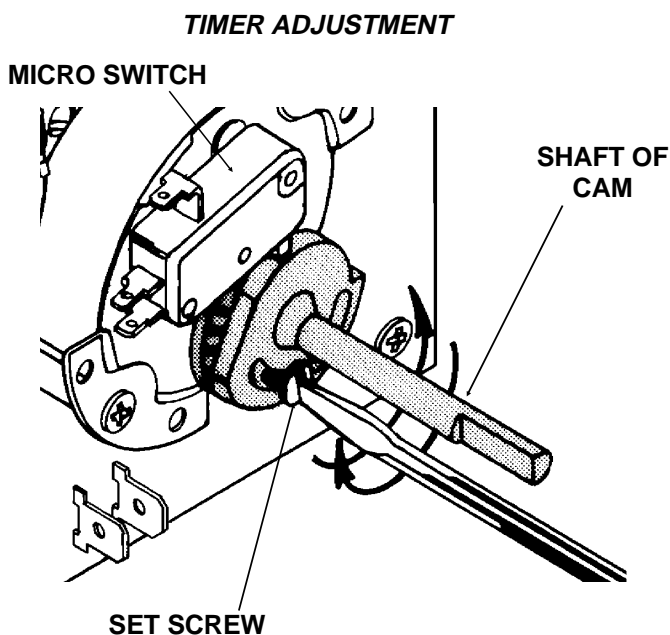
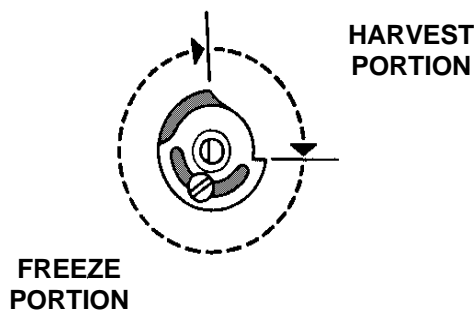
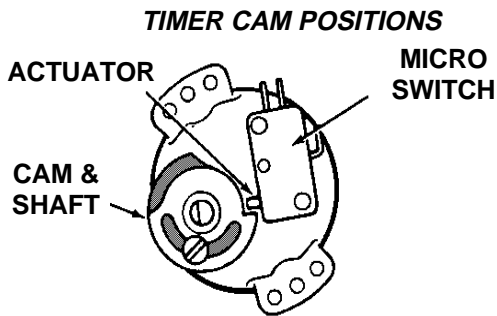

Adjustment Of The Timer & Switch Assembly

One complete revolution of the cam on the timer represents eight minutes. If left as factory set, four and one-half minutes comprise the freezing cycle portion during cam rotation, and the final three and one-half minutes is the defrost/harvest cycle. Rotating the shaft of the timer cam clockwise will put the ice machine in the freeze or harvest cycle.

▲WARNING

Disconnect electrical power before beginning.

To adjust the timer & switch assembly:

1. Remove front panel.
2. Remove control box cover.
 - A. To start the HARVEST CYCLE: Slowly rotate the shaft of the timer and switch assembly clockwise until the actuator arm on the micro switch begins the harvest cycle.
 - B. To start the FREEZING CYCLE: Slowly rotate the shaft of the timer and switch assembly clockwise, until the actuator arm on the micro switch starts the freezing cycle.
 - C. To adjust the length of the harvest cycle:
 1. Loosen the adjustment screw on the cam, and rotate the shaft of the cam to move the top part of the assembly. More of a gap between the high and low portions will yield more harvest time.
 2. Tighten the set screw.
3. Replace the control box cover and front panel.

It is important that the length of the harvest cycle allow enough time for all the ice cubes to fall from the evaporator. Too short of a time will cause the evaporator to freeze up and stop harvesting ice. Too much time wastes ice making capacity, energy and water. Adjustment of the harvest cycle may require an adjustment of the cube size control.

Adjust Bin Ice Level

1. Locate ice level control switch.
2. Move switch to the desired position.
3. To test, wait until the ice machine is near the end of a "harvest" cycle, if there is ice in the bin higher than the position the ice level control is set for, the ice machine will turn OFF at the end of the harvest cycle. If no ice in the bin, test again as described under, "To Test The Ice Level Setting".

COMPONENT DESCRIPTION

Compressor Contactor

The compressor contactor carries the compressor line current. The contactor is wired so any control in the pilot circuit, such as the bin control, and high pressure controls, etc., will cause the contactor holding coil to be de energized, when the control contact OPENS, thereby breaking the circuit to the compressor.

Cube Size Control

This reverse acting (closes on temperature fall) thermostat determines how long the freezing cycle will be. The cube size control closes its contacts when the evaporator cools to the set temperature, starting the timer. A variation in heat load (either ambient air or incoming water temperature) will affect the efficiency of the refrigeration system, and that will vary the length of time it takes the evaporators to cool to the temperature at which the cube size control is set to close, which, in turn, will affect the overall cycle time. See CUBE SIZE ADJUSTMENT BEFORE attempting to adjust the control.

Relay

The multi-function, three pole, double throw, relay plugs into a socket on the printed circuit board in the control box. The relay functions in part to by-pass the bin control during the harvest and freeze cycles, preventing the ice maker from shutting off in the middle of a cycle. The bypass action allows only complete freeze and harvest cycles; the only time that the ice maker can shut off on bin control is as the end of the harvest cycle.

Timer - Timer & Switch Assembly

The timer begins to turn when activated by the cube size control. The outer surface, or large diameter lobe of the timer cam, determines the length of time for finish freezing of the ice cubes, while the inner surface, or small diameter lobe, determines length of the harvest cycle. The single-pole, double throw micro switch on the timer controls the power to the plug in relay coil, making it either the freezing or harvest cycle. The micro switch is actuated by a cam assembly directly connected to the timer motor. The timer cam can be adjusted to vary the defrost time, as required. One complete rotation of the cam will take eight minutes. Harvest is preset at 2 and a quarter minutes.

Hot Gas Solenoid Valve

The hot gas solenoid valve opens only during the harvest cycle. When it opens, it diverts the hot discharge gases so that they flow directly into the evaporator plates, by-passing the condenser and thermostatic expansion valve. The hot gases warm the evaporators, releasing the ice cubes from the ice cube molds. The hot gas solenoid valve is installed in a branch of the discharge line from the compressor, and when the timer switches the ice machine into the harvest cycle, the energized solenoid coil lifts the valve stem within the valve body, allowing the hot discharge gas to be diverted to the evaporators.

High Temperature Cut Out

This temperature sensor is located next to the hot gas valve, on the outlet side.

During normal operation, it does not affect the ice machine, but it will shut the machine off if the hot gas line overheats. It is an automatic reset.

CME865R & CME1002R

COMPONENT DESCRIPTION

Ice Level Control

This electronic control uses sound waves to measure the distance between the bottom of the ice machine and the top of the ice in the bin. It is designed to control the machines ice production to maintain that distance.

The control is adjustable so that the ice machine will maintain a certain height of ice. It will not fill any closer to the ice machine than 8", and will not work if the distance to the bottom of the bin is greater than 8 feet.

Because it uses sound waves, a slight "ticking" sound can be heard coming from the bottom of the machine.

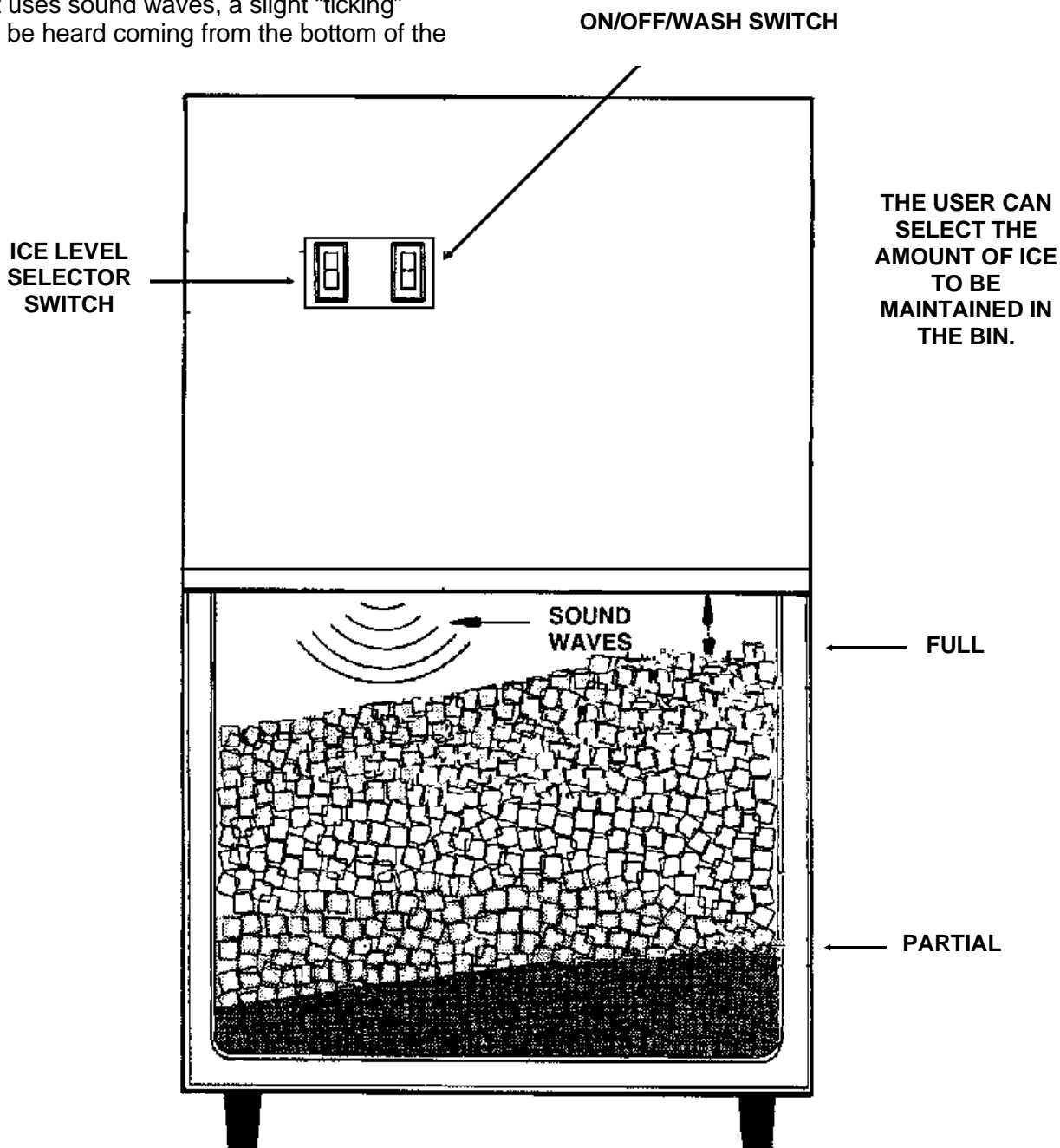

COMPONENT DESCRIPTION

Electric Water Inlet Valve

The water inlet solenoid valve fills the reservoir assembly with water. Excess water overflows out the overflow standpipe located at the back of the reservoir. This action fills and rinses the reservoir during each harvest cycle. The flow rate is .75 g.p.m.

Water Distribution System

The water distribution system evenly supplies water to all cells of the evaporator plates. The water pump pumps water from the reservoir up the vertical tygon tube to the tee. From there water is channeled through the water manifold to the water distributors, above each evaporator plate, and from six holes within each distributor, water flows to the cells of each side of the evaporator plates. Gravity flow returns the unfrozen excess portion of water to the reservoir for recirculation.

Reservoir

The reservoir, located below the evaporators, stores the inlet water charge, and collects the water that flows over the evaporator plates.

High Pressure Safety Control

This is a manual reset control that shuts down the ice maker, should the discharge pressure ever reach 450 PSIG.

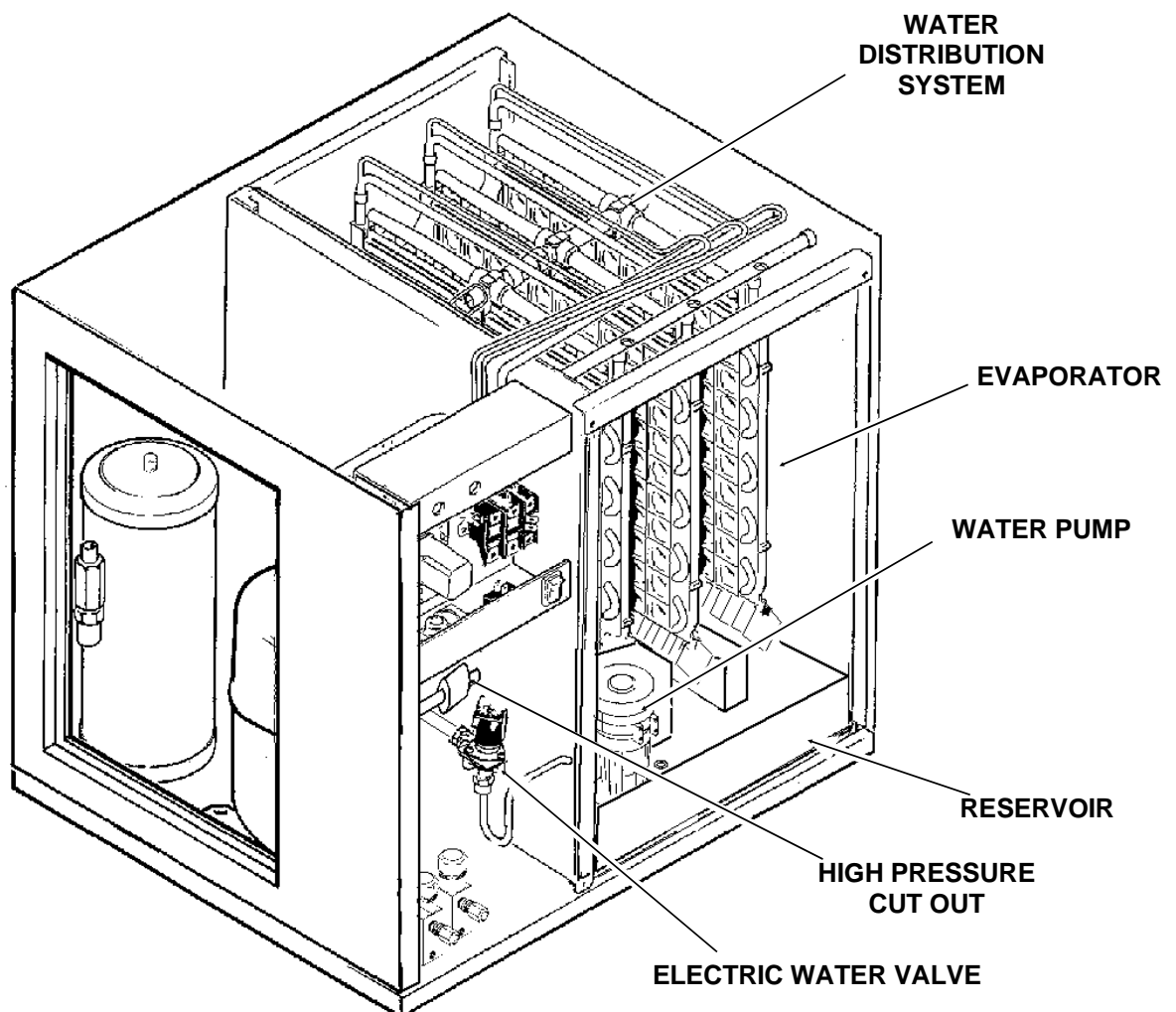

CME865R & CME1002R

SERVICE SPECIFICATIONS: CME865R

The following numbers may be used as a guideline. There will be some variation from unit to unit. Numbers = (Condenser/Cabinet/Water).

| | 0/70/55 | 90/90/70 | 120/110/100 |
|--|--------------------------------|-----------------|-----------------|
| Typical Cycle Time | 14 - 15 minutes | 15 - 16 minutes | 26 - 27 minutes |
| Harvest Time (2 $\frac{2}{3}$ min. standard) | 3 $\frac{1}{4}$ minutes needed | 2 minutes | 2 minutes |
| Typical Freeze Cycle Low Side Pressure (end of cycle) | 26 PSIG | 28 PSIG | 35 PSIG |
| Typical Freeze Cycle Discharge Pressure (end of cycle) | 210 PSIG | 235 PSIG | 330 PSIG |
| Typical Harvest Cycle Low Side Pressure (peak) | 75 PSIG | 100 PSIG | 160 PSIG |
| Typical Harvest Cycle Discharge Pressure (min) | 150 PSIG | 200 PSIG | 292 PSIG |

Typical Total Amps

- 5 minutes into freeze: 8.4
- End of harvest: 11.8

Refrigerant Charge

- 288 oz of R-404A

High Pressure Cut Out

- 450

Typical Harvest Ice Weight

- 8.2 - 8.5 lb.

Pump Down Pressure Switch

- Closes at 35 PSIG
- Opens at 15 PSIG

Cube Size Control

- Cut In adjustable between 12.5°F. and 24°F.

CME865R & CME1002R

SERVICE SPECIFICATIONS: CME1002R

The following numbers may be used as a guideline. There will be some variation from unit to unit. Numbers = (Condenser/Cabinet/Water).

| | 0/70/55 | 90/90/70 | 120/110/100 |
|--|--------------------------------|-----------------|-----------------|
| Typical Cycle Time | 13 - 14 minutes | 14 - 15 minutes | 25 - 26 minutes |
| Harvest Time (2 $\frac{2}{3}$ min. standard) | 3 $\frac{1}{4}$ minutes needed | 2 minutes | 2 minutes |
| Typical Freeze Cycle Low Side Pressure (end of cycle) | 25 PSIG | 24 PSIG | 33 PSIG |
| Typical Freeze Cycle Discharge Pressure (end of cycle) | 210 PSIG | 240 PSIG | 350 PSIG |
| Typical Harvest Cycle Low Side Pressure (peak) | 84 PSIG | 100 PSIG | 150 PSIG |
| Typical Harvest Cycle Discharge Pressure (min) | 170 PSIG | 190 PSIG | 270 PSIG |

Typical Total Amps

- 5 minutes into freeze: 9.9
- End of harvest: 13.6

Refrigerant Charge

- 288 oz of R-404A

High Pressure Cut Out

- 450

Typical Harvest Ice Weight

- 8.2 - 8.5 lb.

Pump Down Pressure Switch

- Closes at 35 PSIG
- Opens at 15 PSIG

Cube Size Control

- Cut In adjustable between 12.5°F. and 24°F.

CME865R & CME1002R

CLEANING & SANITIZING

A Scotsman Ice System represents a sizable investment of time and money in any company's business. In order to receive the best return for that investment, it **MUST** receive periodic maintenance. Maintenance and Cleaning should be scheduled at a minimum of twice per year.

CLEANING: ICE MAKER

1. Remove front panel.
2. Switch the Wash/Off/Ice switch to OFF.
3. Remove the front liner.
4. Remove and discard all ice from the storage bin.
5. Locate the reservoir drain cap, remove the cap and drain the reservoir. Replace the drain cap. If the reservoir doesn't drain completely, disconnect the pump hose attached to the water distributors and place the end of the hose in a bucket. Switch the Wash/Off/Ice switch to Wash, and allow the pump to discharge the rest of the water. Reattach the hose to the water distributors.
6. Mix 8 ounces of Scotsman Ice Machine Cleaner with 1 gallon of warm (95⁰F. - 115⁰F.) water and pour into the reservoir until full.

12. Switch the Wash/Off/Ice switch back on.
13. Replace the front panel
14. Check the next batch of cubes to make sure all of the acid taste is gone.

CAUTION

DO NOT use ice produced from the cleaning solution. Be sure none remains in the bin.

15. Remove and discard all ice from the storage bin, pour hot water into the storage bin to melt the cubes and also clean out the bin drain.
16. The unit is now ready for continued automatic operation.

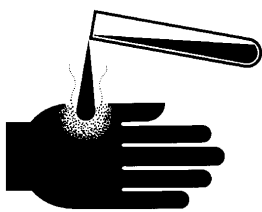
| | |
|---|--|
| ▲WARNING | Scotsman Ice Machine Cleaner contains acids. These compounds may cause burns. |
|  | If swallowed, DO NOT induce vomiting. Give large amounts of water or milk. Call Physician immediately. In case of external contact, flush with water. KEEP OUT OF THE REACH OF CHILDREN. |

7. Switch the Wash/Off/Ice switch to "wash". Let the unit operate for 30 minutes, then switch the unit off.
8. Drain the reservoir again (repeat step 5).
9. Switch the machine to "wash" and continue to add fresh water to flush residual cleaner from the system. Switch the Wash/Off/Ice switch off.
10. Sanitize the ice maker and bin, see "Sanitize Water System".
11. Replace the front liner.

CLEANING

SANITIZE WATER SYSTEM

1. Remove and discard all ice from the bin.
2. Remove front panel.
3. Drain the reservoir
4. Prepare 2 gallons of an approved sanitizer solution in accordance with the instructions on the package.
5. Pour 1 gallon of the sanitizer into the ice maker reservoir.
6. Move the main switch to "Wash", and allow the solution to circulate for a MINIMUM of 5 minutes.
7. Move the main switch to "Off".
8. Pull out the drain plug and drain the reservoir.
9. Using a clean sponge and the remainder of the sanitizer solution, wipe the interior of the evaporator cover and the inside of the storage bin, taking care to wipe all surfaces that are normally in contact with ice.
10. Replace the evaporator cover. Replace the front panel.
11. Move the master switch to ON.

SCOTSMAN REMOTE CONDENSER

1. Disconnect electrical power at the ice maker.

▲WARNING

Disconnect electrical power before beginning.

2. Wipe off any surface dust from the intake side of the condenser.
3. Vacuum the coil, or clean with coil cleaner.
4. The coil is clean when light can be seen through the fins.
5. Reconnect electrical power.

SANITIZE ICE STORAGE BIN

This procedure is to be done monthly

1. Remove and discard all ice from the bin.
2. Switch the ice maker off.
2. Prepare 2 gallons of an approved sanitizer solution in accordance with the instructions on the package.
3. Using a clean sponge wipe the inside of the storage bin and door, taking care to wipe all surfaces.
4. Rinse the interior of the storage bin using clean water and the sponge used in step 3.
5. Switch the ice machine back on.

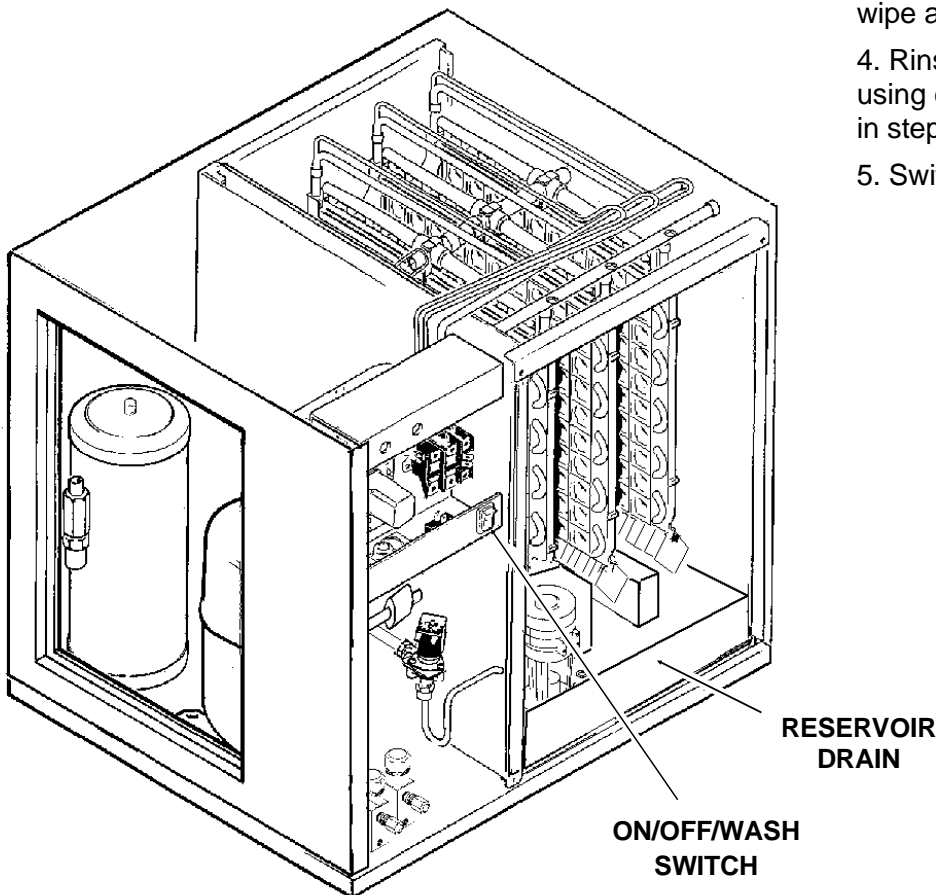

CME865R & CME1002R

FREEZING CYCLE OPERATION

Water from the sump assembly is pumped to the water distributor system at the top of each evaporator plate. From the water distributor the water cascades by gravity over all cells of the plate and to the sump assembly below.

At the beginning of the freezing cycle the water pump, fan motor and compressor have power. The water pump operates continuously, through both the freezing cycle and the harvest cycle.

During the freezing cycle, the hot gas solenoid valve and the water inlet solenoid valve are CLOSED. When the ice cubes are partially formed, the cube size control will CLOSE. This will complete an electrical circuit to the timer motor. The timer will keep the ice maker operating in the freezing cycle for a selected length of time. This will give the ice cubes time to fully form. After that selected length of time, the timer will switch the ice maker into the harvest cycle, through the contacts of the timer assembly micro switch.

Low Temperature Freeze:

When the outside air temperature is low, the Head Pressure Regulator will close off the liquid line to the receiver, causing liquid refrigerant to back up into the condenser until the head pressure builds up to 220 PSIG. While this is occurring, the head pressure regulator passes discharge gas into the receiver to keep the refrigerant flowing.

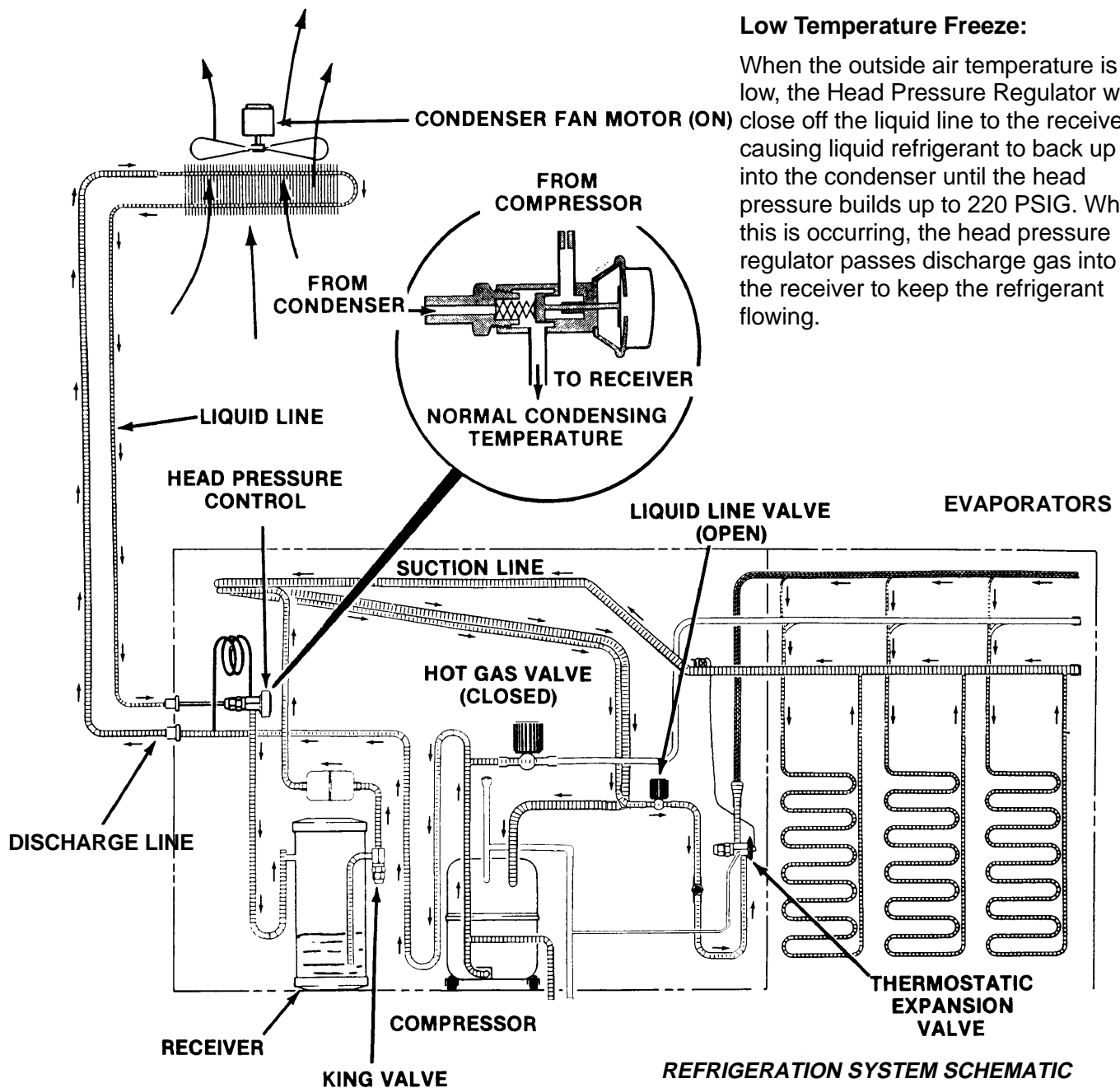

HARVEST CYCLE - HOT GAS BYPASS

When the timer switches the ice maker into the harvest cycle, high pressure, high temperature refrigerant gas being discharged from the compressor is diverted from the condenser through the hot gas solenoid valve into each evaporator plate. During this cycle, the refrigerant bypasses the condenser. In the electrical circuit, both the compressor and the water pump are operating and the hot gas solenoid valve is energized and OPEN and the water inlet solenoid valve is OPEN.

The finished ice cubes are released from the sides of each evaporator plate by the warming effect of the hot gas condensing in each evaporator plate and the water cascading over the ice cubes. The released ice cubes drop into the ice storage bin below. At the end of the harvest cycle, the timer cam will push the actuator arm to the micro switch IN. If the ice level control is still CLOSED, a whole new cycle will begin. If the ice level control is OPEN, the ice maker will begin to shut OFF.

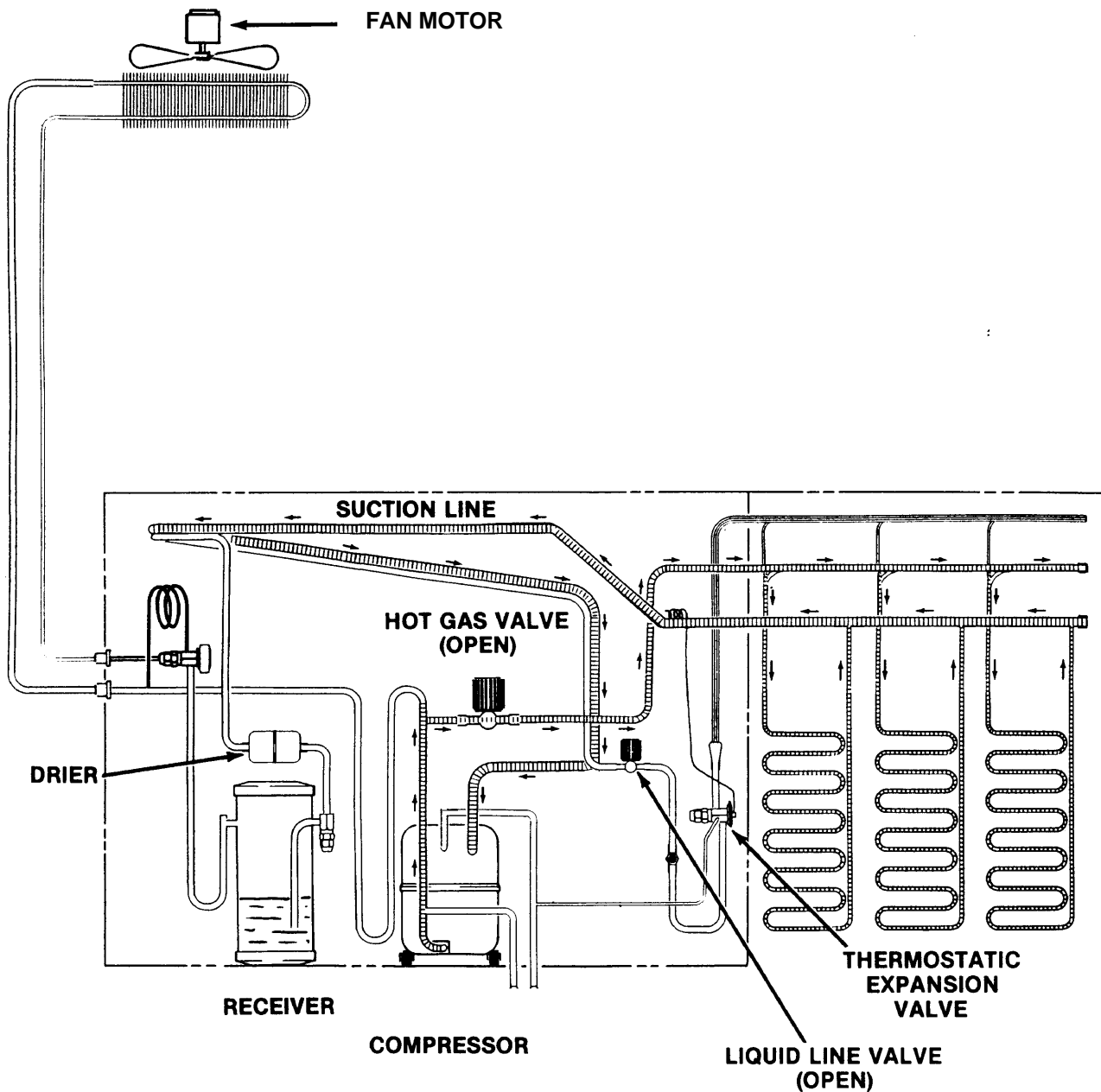

REFRIGERATION SYSTEM SCHEMATIC

CME865R & CME1002R

SERVICE DIAGNOSIS

| SYMPTOM | POSSIBLE CAUSE | PROBABLE CORRECTION |
|--|---|---|
| No ice, machine does not run | 1. No electrical power | 1. Restore power |
| | 2. Circuit breaker tripped or fuse blown | 2. Reset breaker or replace fuse, check for electrical fault. |
| | 3. High pressure control open. | 3. Reset HPC, check fan motor for proper operation, and condenser coil for dirt. |
| | 4. Bin level control holding machine off | 4. Check ice level control circuit. See page 25. |
| | 5. High temp. cut out open | 5. Hot gas valve leaks thru, replace hot gas valve |
| | 6. Timer switch open | 6. Replace timer |
| | 7. On/Off switch open | 7. Check or replace switch. |
| | 8. Circuit board open | 8. Replace circuit board. |
| No ice, compressor does not run, rest of ice machine does. | 1. Compressor on/off switch open | 1. Check or replace switch |
| | 2. Open contactor coil | 2. Replace contactor |
| | 3. Liquid line valve does not open | 3. Check electrical connections to liquid line valve, check coil, check valve operation |
| | 4. Pump down pressure switch does not close | 4. Defective switch, or liquid line valve does not open, or low on refrigerant; check/replace |
| | 5. Thermostatic Expansion valve clogged or does not open. | 5. Check/replace TXV. |
| No ice, no water over evaporators | 1. Water pump does not pump | 1. Check/replace water pump |
| | 2. No water in reservoir | 2. Check/replace water inlet valve. |
| No ice, everything runs | 1. Too much heat load | 1. Check for slow leak thru of water inlet valve. |
| | 2. Low on refrigerant | 2. Check pressures, if low find/repair leak. weigh in charge. |
| | 3. Suction pressure too high | 3. Defective compressor - replace |
| Low ice production | 1. Too much heat load. | 1. Check condenser air inlet and water temperatures. |
| | 2. Compressor inefficient. | 2. Replace compressor |
| | 3. Non condensable gasses in refrigeration system. | 3. Check head pressure, if very high, and no other reason is suspected, replace refrigerant charge. |

CME865R & CME1002R

SERVICE DIAGNOSIS

| SYMPTOM | POSSIBLE CAUSE | PROBABLE CORRECTION |
|--|---|--|
| Low ice production | 3. High head pressure, a result of a dirty condenser | 3. Clean condenser, check fan motor |
| | 4. Hot gas valve leaks thru | 4. Replace hot gas valve |
| | 5. High air temp. for condenser. | 5. If possible, reduce condenser air inlet temperature. |
| No ice falling in bin, unit frozen up | 1. Cube size control will not close | 1. Check temp. of suction line, cube size control will not close if temp. too high. If temp. low enough, replace cube size control |
| | 2. Timer motor open | 2. Replace timer |
| | 3. Plug in relay contacts open | 3. Replace relay |
| | 4. Not enough time during the harvest cycle to drop all ice | 4. Adjust timer for more harvest time |
| | 5. Cube size wrong | 5. Adjust cube size |
| | 6. Hot gas valve restricted. | 6. Replace hot gas valve. |
| | 7. Not enough water to help harvest. | 7. Check for restriction of water supply. |
| | 8. Head pressure too low | 8. Check pressure control valve. Check for low refrigerant charge. |
| Ice maker stuck in harvest cycle | 1. Relay coil open | 1. Replace relay |
| | 2. Timer stuck in harvest cycle | 2. Check for power to timer motor, if power replace timer, if no power to timer motor, replace relay. |
| | 3. Timer micro switch N.O. contacts will not close. | 3. Replace timer. |
| Ice is mal-formed | 1. Shortage of water | 1. Check for restriction of water supply. Check for leak. |
| | 2. Evaporator water passages restricted. | 2. Clean ice maker. |
| | 3. Cube size set wrong | 3. Adjust cube size control |
| Water overflows from reservoir into bin. | 1. Restricted sump drain | 1. Repair drain |
| | 2. Inlet water valve lets in too much water | 2. Replace valve |

CME865R & CME1002R

SERVICE DIAGNOSIS: Ice Level Control Circuit

| CONDITION | DETERMINE CAUSE | PROBABLE CORRECTION |
|--|--|---|
| Ice Machine does not run, it has power to it, the high pressure control is closed, the on/off switch is set to ON (the compressor will not operate until the liquid line valve opens, but the pump should be working if there is no ice in the bin). | A. Listen for a ticking sound from transducer. | If no noise, go to C. If there is a noise, check for a light on the board. If there is a light on, check relay contacts N.O. and COM. The contacts should be CLOSED. If closed, go to D. If not, replace the board. If light is off, or prior model, go to B. |
| | B. Open bin door and twist transducer 1/4 turn and pull out. DO NOT UNPLUG with power connected. Examine the transducer, the inside must be clean and dry. | If the inside of the transducer (above screen) was wet, replace it. Set bin level to FULL and aim at an object about 1-3 feet away. Machine should restart, if not go to D. |
| | C. Check power to bin level control board. | Should be 12 volts from transformer, if not replace transformer. If there is power go to D. |
| | D. Disconnect electrical power and test ice machine circuit by attaching a jumper wire between bin thermostat posts on circuit board part no. 12-1912-01 (the circuit board with the timer on it). Reconnect power. | If machine does not start go back to machine circuit. If machine starts, disconnect electrical power, remove jumper wire and reconnect electrical power. Then go to E. |
| | E. Transducer or ice level board assembly defective. | Replace transducer. Set bin level to FULL and aim at an object about 1-3 feet away. Machine should restart. If this does not repair unit, replace the board. |
| Machine runs, makes ice, switches on and off, but ice level cannot be controlled. | Ice level switch may be defective. | Replace ice level switch |

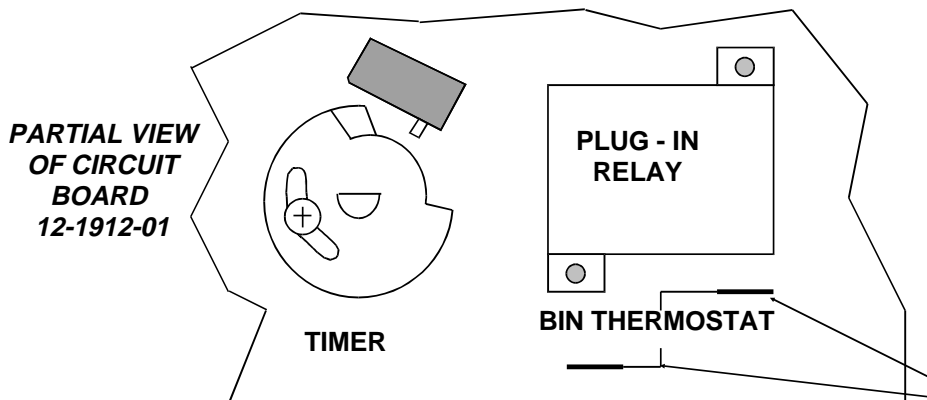

⚠ WARNING
Electrical Shock Hazard
 Can Cause Personal Injury.
 Disconnect Power Before Servicing.
 Bin Thermostat Posts at Line Voltage.

**POSTS MENTIONED IN
 "D" ABOVE**

Sonar

- ◆ Sonar is Scotsman's ultrasonic device for measuring ice level and switching the ice machine on and off.
- ◆ It consists of a control board, transducer, level selector switch and transformer.

Sonar Service Diagnosis

- ◆ Step 1. Determine if it's a bin control problem.
 - Machine will not switch on
 - ❖ Reset high pressure cut out
 - ❖ Jump the two posts on the circuit board marked "bin thermostat".
 - ❖ If the machine starts, the sonar system needs to be checked out.
 - If the machine does not start, something else is wrong.



Sonar Service Diagnosis

- ◆ Step 2: If it is a sonar problem, check the board.
 - 12 volts to board.
 - ❖ If not, check the transformer.
 - When ice is called for, the relay contacts are CLOSED.
 - ❖ Check the relay on the board. COM to NO should be closed. If they are open, REPLACE THE BOARD - NOT THE TRANSDUCER



Sonar Service Diagnosis

◆ Step 3. If the red light is NOT ON

– Check the selector switch and harness.

- ❖ Jump out the two outside pins on the board where the selector switch harness plugs on.
- ❖ The indicator light should come on and the machine should start.

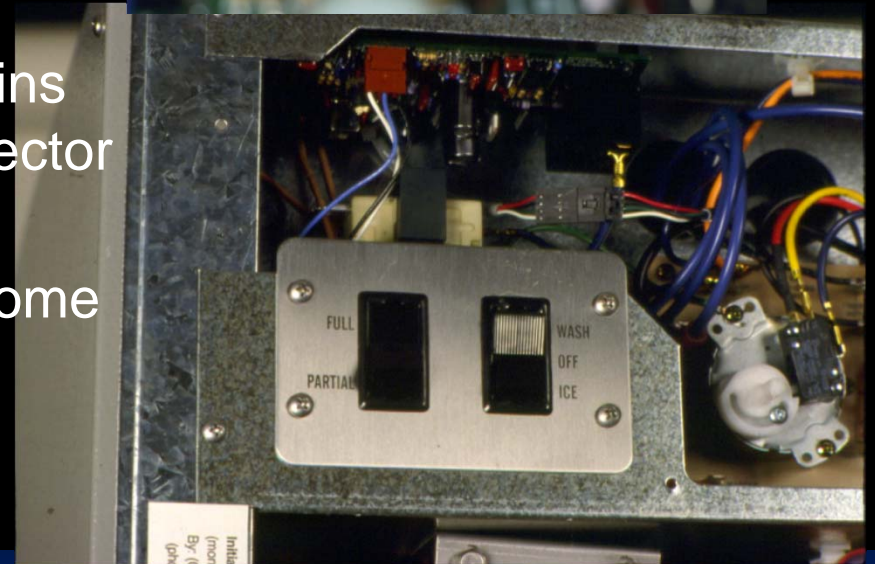
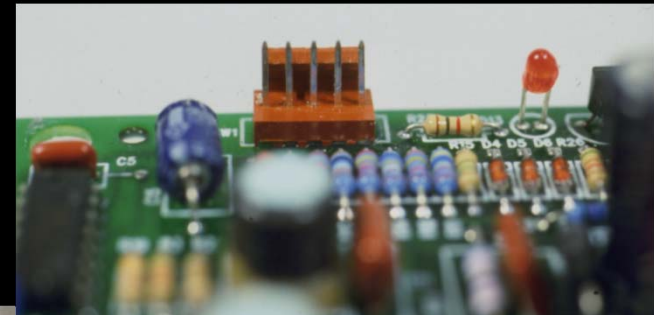

Sonar Service Diagnosis

- ◆ Step 4: If the red light is not on, and jumping the two outside pins does not work, check the transducer.
 - CME1202 or CME1402: Twist and pull the transducer UP to remove it.
 - CME865 and CME1002: Twist and pull the transducer DOWN to remove it.

Sonar Service Diagnosis

◆ Transducer Check

- “Ticking” sound is normal
- Examine the screen and face of the transducer.
 - ❖ If the screen is dirty, clean it.
 - ❖ If the face of the transducer is wet, dry it and try it again.
 - ❖ If the face of the transducer is wrinkled, replace the transducer
- NOT THE BOARD.

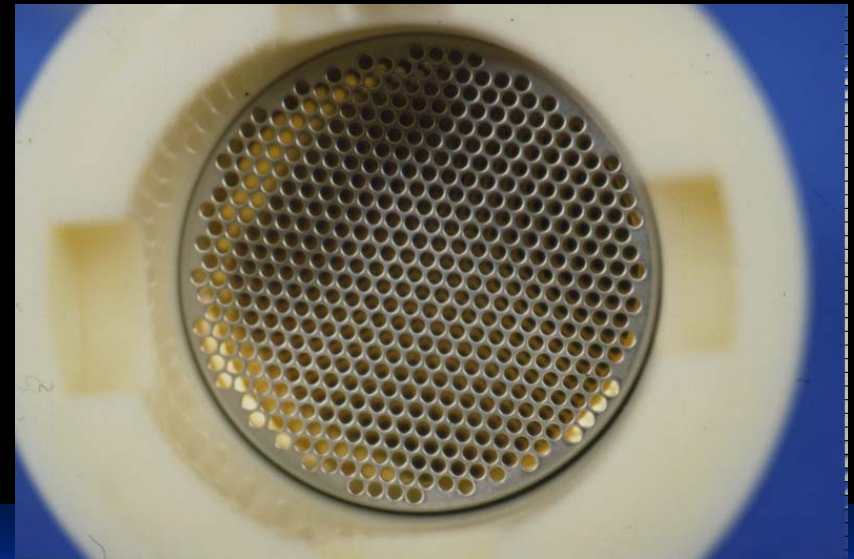

Sonar Service Diagnosis

◆ Transducer Check

- ❖ Switch power on and check the transducer against a hard, flat surface.
- ❖ Try a NEW transducer, if that does not fix the machine, replace the BOARD, but re-use the original transducer.
- It is VERY UNLIKELY that BOTH the transducer and the BOARD have failed at the same time.

Sonar Service Diagnosis

Check Transducer Resistor (green and white wires)
- should be about 260-270 ohms.

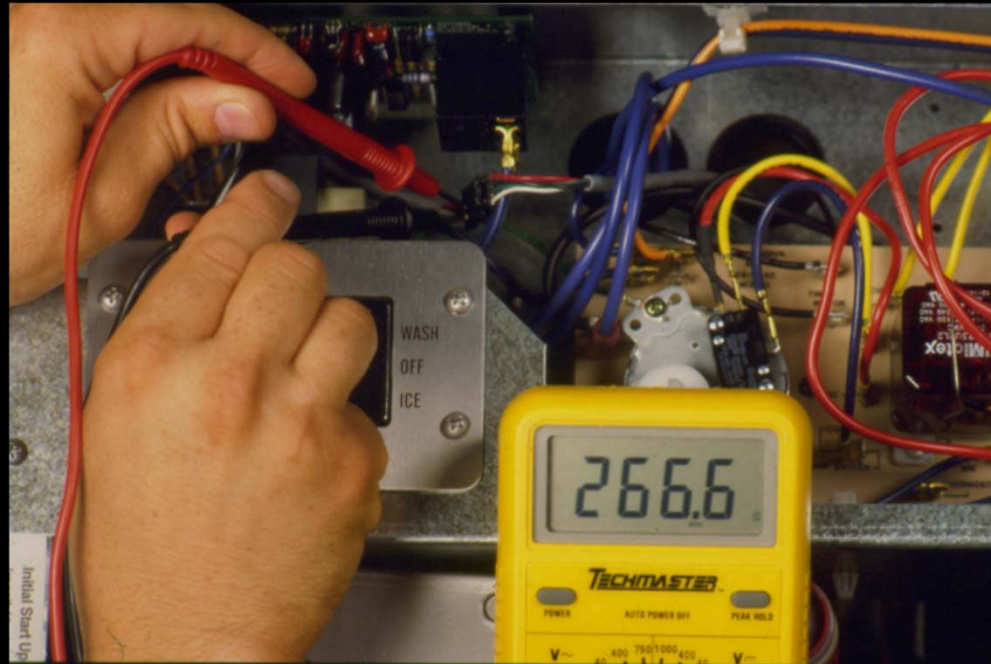

REMOVAL AND REPLACEMENT

TRANSDUCER

1. Disconnect electrical power BEFORE removing transducer.
2. Open bin door and locate the transducer socket.
3. Twist inner portion of transducer counter-clockwise and push up gently.
4. Pull transducer down until plug connection is accessible.
5. Unplug transducer and remove from the machine.
6. Reverse steps 1-5 to reassemble.

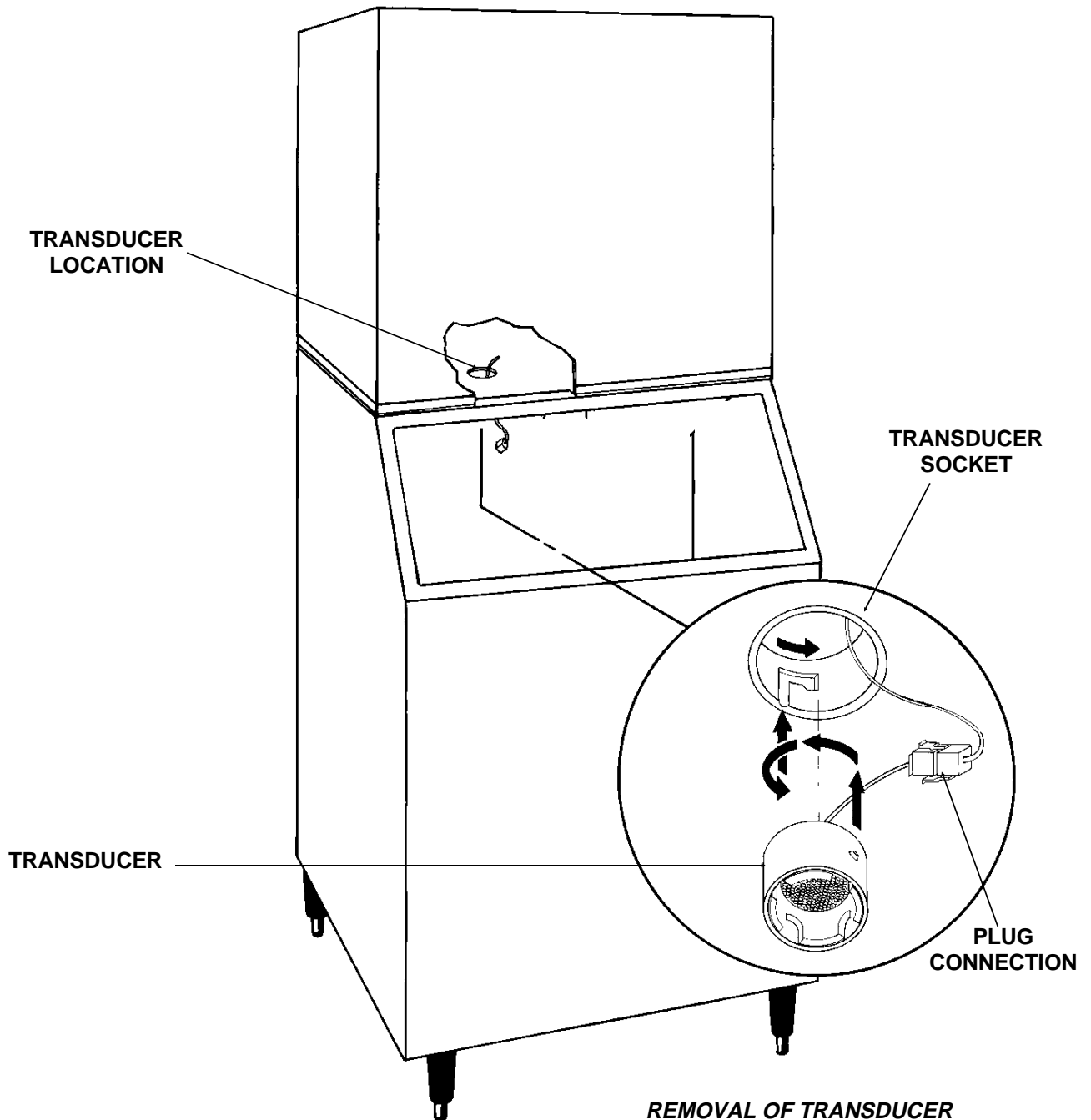

CME865R & CME1002R

REMOVAL AND REPLACEMENT

▲WARNING

Disconnect electrical power before beginning.

Water Distributor Tubes And Manifold Tubes

To remove the water distributor tube and manifold tube:

1. Pull out to unsnap catches and remove the front panel.
2. Remove the evaporator cover.
3. Slide the water distributor tube to the front about 1/8-inch along the top of the evaporator plate, until the water distributor tube can be unsnapped from the flexible notch and lifted upward to the right side.
4. Unsnap and disconnect water distributor tubes from the water manifold section. To replace the water distributor tubes and manifold tubes, reverse the removal procedure. **BE SURE** the notches in the water manifold tubes properly engage the alignment keys in the tee. **BE SURE** the water distributor tube is securely fastened at the notch at both sides of the evaporator plate. Check identical attachment for the left water distributor tube and notch; also, that the distributor/manifold connections at the top center of each evaporator plate is snug against the top of the plate.

Cube Size Control

To remove the cube size control:

1. Remove front panel.
2. Remove cover from control box.
3. Trace capillary tube, from the cube size control to the refrigerant suction line.
4. Remove the coiled capillary tube bulb from the tube well on the suction line.
5. Remove electrical leads from the cube size control.
6. Remove screws and the cube size control. To replace the cube size control, reverse the removal procedure. **Be certain** that the bulb is re-insulated.

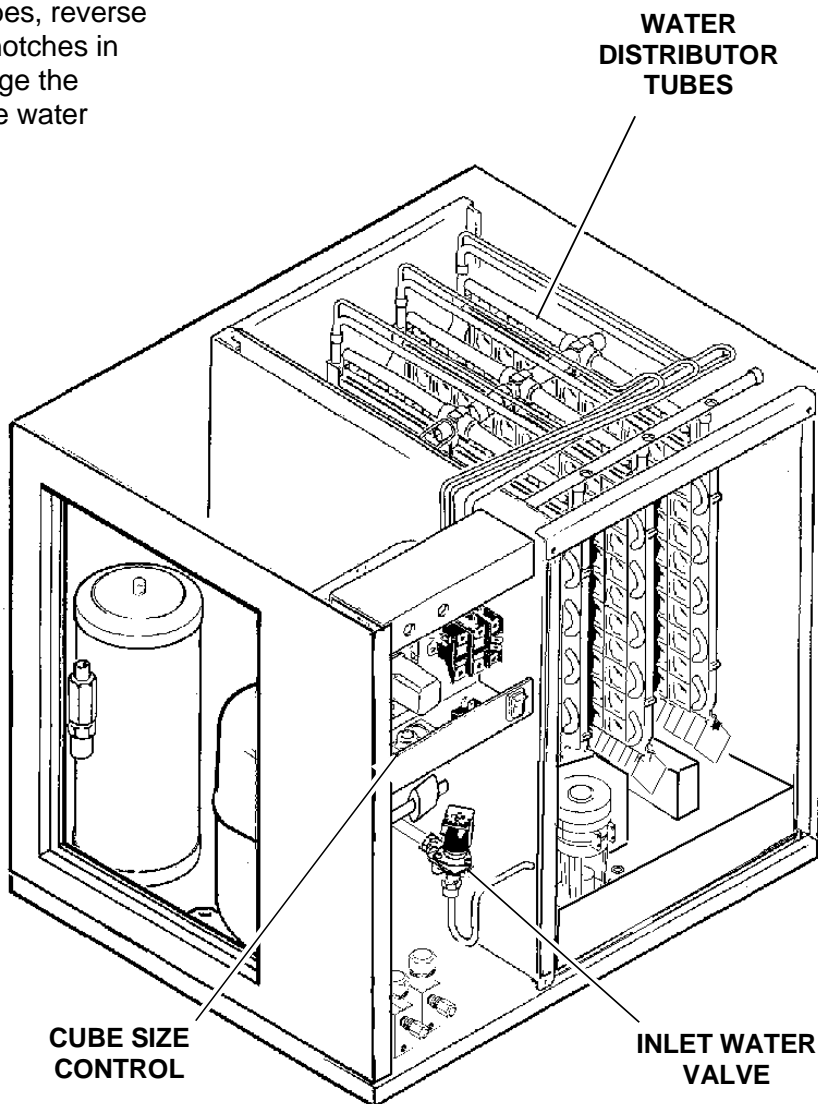

REMOVAL AND REPLACEMENT

⚠ WARNING

Disconnect electrical power before beginning.

Water Pump

1. Remove front panel.
2. Remove evaporator cover.
3. Unplug water pump electrical connection.

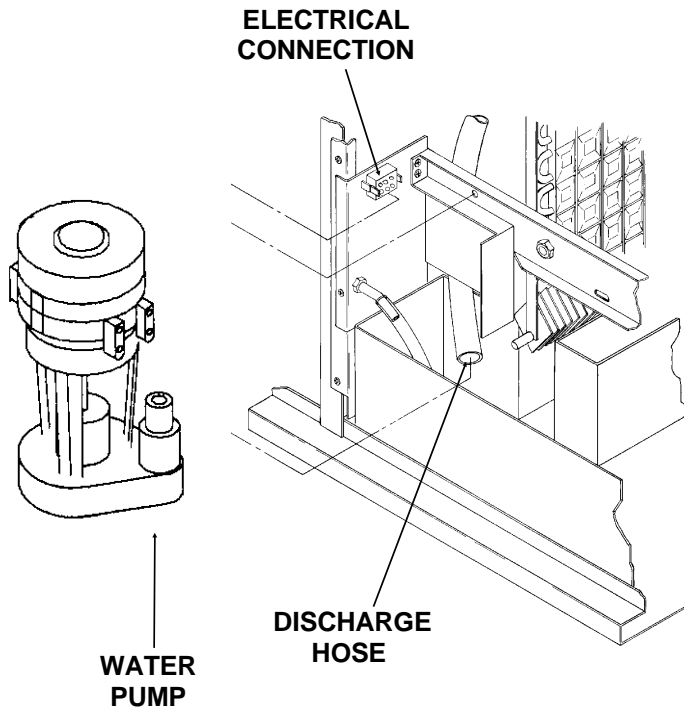

REMOVAL OF THE WATER PUMP

4. Remove thumb screw retaining pump to cross brace.
5. Pull pump partially out of reservoir and remove discharge hose.
6. Remove the pump from the ice maker.
7. Reverse to reassemble.
8. Replace all panels.
9. Reconnect electrical power.

Inlet Water Solenoid Valve Assembly

To remove the inlet water solenoid valve assembly:

1. Shut OFF water supply to machine.
2. Loosen and remove outlet water line from the inlet water solenoid valve assembly.
3. Remove screws and pull the water solenoid valve out to gain access.

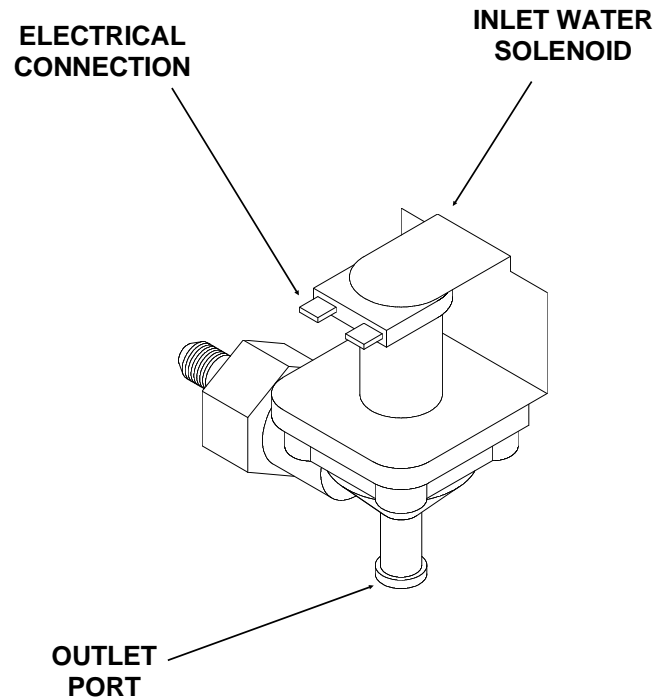

REMOVAL OF INLET WATER SOLENOID VALVE

4. Pull electrical cord from solenoid coil terminals.
5. Remove inlet water fitting from the water solenoid valve. To replace the inlet water valve assembly, reverse the removal procedures.

CME865R & CME1002R

REMOVAL AND REPLACEMENT

Head Pressure Control Valve

1. Remove side service panel, and top panel if possible.
2. Discharge and recover refrigerant from the system.
3. Break off the process tube on the dome of the head pressure control valve.
4. Cut out or unsweat the tubing connections to the valve. Remove the valve.
5. Wrap the new valve in wet cloths or other effective heat sink material, and sweat the tubing connections to the valve.
6. Weigh the nameplate charge into the receiver.
7. Replace all panels.
8. Reconnect electrical power.

Hot Gas Valve or Liquid Line Valve

1. Remove the side service panel, and top panel if possible.
2. Discharge and recover the refrigerant from the system.
3. Remove the electrical connections from the coil of the valve
4. Cut out or unsweat the valve at the tubing connections, remove the valve from the ice maker.
5. Install the new valve, wrap it in wet cloths or other efficient heat sink material.
6. Sweat the tubing connections to the valve.
7. Connect the electrical wires to the terminals of the valve coil.
8. Weigh the nameplate charge into the receiver.
9. Replace all panels removed for service.
10. Reconnect electrical power.

Thermostatic Expansion Valve

1. Remove the side service panel, and top panel if possible..
2. Discharge and recover the refrigerant from the system.
3. Locate the TXV sensing bulb on the suction line, unwrap the insulation and remove the bulb from the clamp.
4. Cut out or unsweat the old TXV from the tubing connections.
5. Wrap the new TXV body in wet cloths or other efficient heat sink material.
6. Re-attach the TXV bulb to the suction line in the same place as the original. Be certain to re-insulate the bulb.
7. Sweat in the new valve. Do not overheat.
8. Weigh the nameplate charge into the receiver.
9. Replace all panels removed for service.
10. Reconnect electrical power.

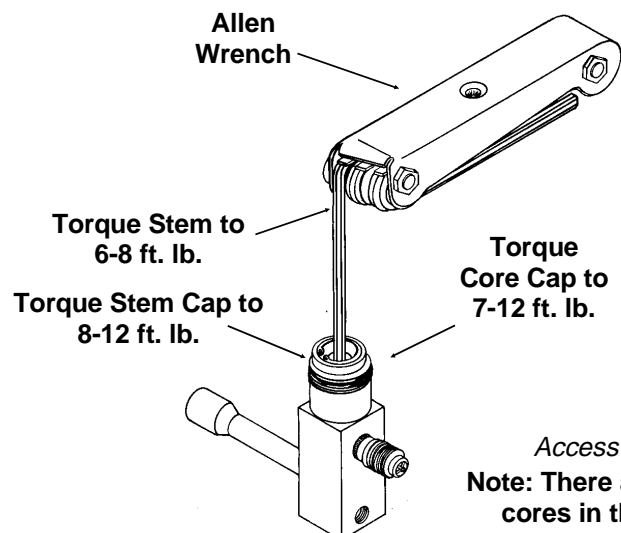

REFRIGERATION SERVICE

This ice machine uses R-404A refrigerant and polyolester oil. Do NOT use mineral oil in this refrigeration system.

- R-404A is a "Near Azeotrope" so liquid charging is required: See the next page.
- When the system is serviced, a special liquid line drier is required. It is included with replacement compressors.
- HP62 is not compatible with mineral oil, so these ice machines use Polyolester oil. Polyolester oil absorbs water very easily. When one of these refrigeration systems is opened for service, it must be re-sealed as soon as possible (15 minutes maximum).
- Special leak detection equipment is required to locate small refrigerant leaks. Usually a leak detector capable of detecting a Halogenated refrigerant or HFC-134A will work. Check with the leak detector manufacturer if in doubt.

Access Valves: To use the access valves:

- Remove the cap from the stem, use a 3/16" allen wrench to check that the valve is CLOSED. Then remove the core cap.
- **Close the valve and replace the caps when the job is finished. The valve must be closed and the caps must be on or the valve will leak.**

General Information:

Work on the refrigeration system should only be done when it is certain that the system needs repair.

- **Refrain from checking refrigeration pressures without reason.** Visual inspection of the water system, observation of the ice formation, amp draw, voltage, and other techniques will lead to proper diagnosis.
- If gauges must be used, don't always check the high side pressure. If the condenser is clean and seems to be operating correctly, it most likely is.
- If gauges must be used, use very short hoses to minimize refrigerant discharged into the air.
- Refrigerant should not be added except as a way to determine the proper operation of the product. If the system was low on refrigerant, there is a leak, and it must be found and repaired.
- This system has a critical charge, it must be recharged with the correct amount of refrigerant as listed on the nameplate of the ice machine, or performance will suffer.
- Anytime the refrigeration system has been opened, the dryer should be replaced. **Note: Only a HFC type dryer can be used.**
- When brazing the tubing connections to components such as the TXV, the component must be protected by heat sink material.

Recover, reclaim or recycle refrigerant. The method chosen is up to the service company. Any refrigerant placed into a Scotsman ice machine must meet ARI spec 700-88. Reclaim programs are available through most refrigerant wholesalers.

Pressure-Temperature Chart for HP62

| | VAPOR | | VAPOR | |
|---------|--------|--------|--------|--|
| TEMP. | PRES. | TEMP. | PRES. | |
| (DEG F) | (PSIG) | DEG F) | (PSIG) | |
| -20 | 17 | 70 | 146 | |
| -18 | 18 | 72 | 150 | |
| -16 | 20 | 74 | 155 | |
| -14 | 21 | 76 | 161 | |
| -12 | 23 | 78 | 166 | |
| -10 | 24 | 80 | 171 | |
| -8 | 26 | 82 | 177 | |
| -6 | 28 | 84 | 182 | |
| -4 | 29 | 86 | 188 | |
| -2 | 31 | 88 | 194 | |
| 0 | 33 | 90 | 200 | |
| 2 | 35 | 92 | 206 | |
| 4 | 37 | 94 | 212 | |
| 6 | 39 | 96 | 219 | |
| 8 | 41 | 98 | 225 | |
| 10 | 43 | 100 | 232 | |
| 12 | 46 | 102 | 239 | |
| 14 | 48 | 104 | 246 | |
| 16 | 50 | 106 | 253 | |
| 18 | 53 | 108 | 260 | |
| 20 | 55 | 110 | 268 | |
| 22 | 58 | 112 | 275 | |
| 24 | 60 | 114 | 283 | |
| 26 | 63 | 116 | 291 | |
| 28 | 66 | 118 | 299 | |
| 30 | 69 | 120 | 307 | |
| 32 | 72 | 122 | 316 | |
| 34 | 75 | 124 | 324 | |
| 36 | 78 | 126 | 333 | |
| 38 | 81 | 128 | 342 | |
| 40 | 85 | 130 | 351 | |
| 42 | 88 | 132 | 360 | |
| 44 | 91 | 134 | 370 | |
| 46 | 95 | 136 | 379 | |
| 48 | 99 | 138 | 389 | |
| 50 | 102 | 140 | 399 | |
| 52 | 106 | 142 | 409 | |
| 54 | 110 | 144 | 420 | |
| 56 | 114 | 146 | 430 | |
| 58 | 118 | 148 | 441 | |
| 60 | 123 | 150 | 452 | |
| 62 | 127 | 152 | 464 | |
| 64 | 132 | 154 | 475 | |
| 66 | 136 | 156 | 487 | |
| 68 | 141 | 158 | 499 | |

CME865R & CME1002R

LIQUID CHARGING

Instructions for R-404A

In preparation for charging, the low side hose should have a sight glass, and/or a restrictor device (such as a "Charge Faster") installed in it for metering liquid into the low side of the system.

*The discharge hose should be connected to the receiver's "king" valve for **faster** recovery and recharging.*

1. After a thorough evacuation to at least 200 microns, shut off the manifold valves and switch off the vacuum pump.
2. Place a drum of R-404A onto an electronic scale.
3. Attach the charging hose to the drum.
4. Open the valve on the drum and purge the charging hose.
5. Zero out the scale.
6. Shut the low side access valve at the ice machine.
7. Open the discharge manifold valve full open.
8. Watch the scale, when the correct charge is shown, shut the manifold valve.

Note: If all of the charge will not "go in" the discharge side:

- A. Shut the discharge access valve at the ice machine.
 - B. Switch the machine on.
 - C. Open the low side access valve at the ice machine.
 - D. Open the low side manifold valve and observe the sight glass to be certain that only gas is flowing into the system.
 - E. When the proper charge is indicated on the scale, shut off the manifold valve(s).
9. Shut off the valve on the refrigerant drum.
 10. Re-open the manifold valves until all liquid has flowed out of the hoses.
 11. Shut the low side access valve on the ice machine.
 12. Remove hoses from ice machine and replace all caps.

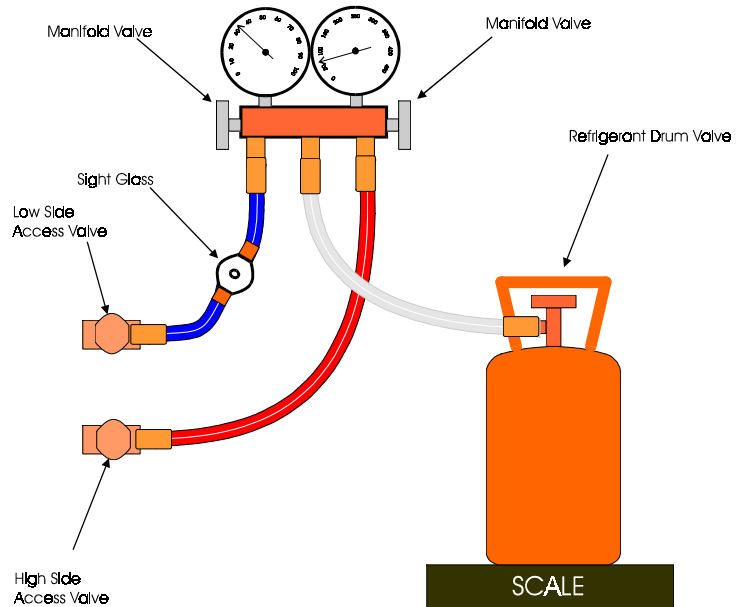

Hose Connection Schematic for Liquid Charging

